



Ballot Vote Sheet

TO: The Commission
Alberta E. Mills, Secretary

DATE: February 15, 2023

THROUGH: Austin C. Schlick, General Counsel
Jason K. Levine, Executive Director

FROM: Daniel R. Vice, Assistant General Counsel, Regulatory Affairs
Mary A. House, Attorney, Regulatory Affairs

SUBJECT: ASTM's Notice of a Revised Voluntary Standard for Non-Full-Size Cribs

BALLOT VOTE DUE: Wednesday, February 22, 2023

Section 104(b)(4)(B) of the Consumer Product Safety Improvement Act of 2008 (CPSIA) sets forth a procedure for updating mandatory standards that incorporate by reference, in whole or in part, a voluntary standard for a durable infant or toddler product. 15 U.S.C. § 2056a(b)(4)(B). This procedure applies to the Safety Standard for Non-Full-Size Baby Cribs, 16 CFR part 1220, which incorporates by reference ASTM F406-19, *Standard Consumer Safety Specification for Non-Full-Size Baby Cribs/Play Yards*, with modifications to exclude requirements that apply solely to play yards. 84 *Fed. Reg.* 56,684 (Oct. 23, 2019).

On December 5, 2022, ASTM notified the Commission that it had approved and published ASTM F406-22 as a revised version of this voluntary standard for non-full-size baby cribs (NFS cribs) and play yards. Under CPSIA section 104(b)(4)(B), revised voluntary standards that have been incorporated automatically are considered consumer product safety standards, unless the Commission determines and notifies the voluntary standards organization that the revised voluntary standard “does not improve the safety of the consumer product.” As discussed in staff’s briefing package, staff recommends that the Commission allow the revised ASTM standard, exclusive of requirements that apply solely to play yards, to become the CPSC-mandated standard for NFS cribs. Specifically, staff recommends that the Commission publish the attached draft direct final rule that revises the reference in CPSC’s safety standard for NFS cribs to refer to ASTM F406-22.

Please indicate your vote on the following options:

- I. Accept ASTM F406-22 as the new mandatory standard for NFS cribs and direct staff to publish the draft *Federal Register* notice to revise the version of the standard incorporated by reference in 16 CFR part 1220.

(Signature)

(Date)

- II. Determine that ASTM F406-22 does not improve the safety of NFS cribs and direct CPSC staff to notify ASTM of this determination and that the Commission is retaining the existing standard for NFS cribs in 16 CFR part 1220.

(Signature)

(Date)

- III. Take other action specified below.

(Signature)

(Date)

Attachment: February 15, 2023 Staff Briefing Package: ASTM's Notice of a Revised Voluntary Standard for Non-Full-Size Baby Cribs

[Billing Code 6355-01-P]

CONSUMER PRODUCT SAFETY COMMISSION

16 CFR Part 1220

[Docket No. CPSC-2019-0025]

Revision to Safety Standard for Non-Full-Size Baby Cribs

AGENCY: Consumer Product Safety Commission.

ACTION: Direct final rule.

SUMMARY: In December 2010, the U.S. Consumer Product Safety Commission (CPSC or Commission) published a consumer product safety standard for non-full-size baby cribs (NFS cribs) pursuant to section 104 of the Consumer Product Safety Improvement Act of 2008 (CPSIA). The Commission's mandatory standard incorporated by reference the ASTM voluntary standard that was in effect for NFS cribs at the time, with modifications to make the standard more stringent, to further reduce the risk of injury associated with NFS cribs, and to exclude sections of the ASTM voluntary standard inapplicable to NFS cribs. The CPSIA sets forth a process for updating mandatory standards for durable infant or toddler products that are based on a voluntary standard, when a voluntary standards organization revises the standard. In November 2022, ASTM published a revised voluntary standard for NFS cribs, and it notified the Commission of this revised standard in December 2022. This direct final rule updates the mandatory standard for NFS cribs to incorporate by reference ASTM's 2022 version of the voluntary standard for NFS cribs.

DATES: The rule is effective on June 3, 2023, unless the Commission receives a significant adverse comment by [INSERT DATE 30 DAYS AFTER DATE OF PUBLICATION IN THE FEDERAL REGISTER]. If the Commission receives such a comment, it will publish a notice in

OS4
DRAFT

the *Federal Register*, withdrawing this direct final rule before its effective date. The incorporation by reference of the publication listed in this rule is approved by the Director of the Federal Register as of June 3, 2023.

ADDRESSES: You can submit comments, identified by Docket No. CPSC-2019-0025, by any of the following methods:

Electronic Submissions: Submit electronic comments to the Federal eRulemaking Portal at: <https://www.regulations.gov>. Follow the instructions for submitting comments. CPSC typically does not accept comments submitted by electronic mail (e-mail), except as described below. CPSC encourages you to submit electronic comments by using the Federal eRulemaking Portal.

Mail/Hand Delivery/Courier/Confidential Written Submissions: Submit comments by mail, hand delivery, or courier to: Office of the Secretary, Consumer Product Safety Commission, 4330 East West Highway, Bethesda, MD 20814; telephone: (301) 504-7479. If you wish to submit confidential business information, trade secret information, or other sensitive or protected information that you do not want to be available to the public, you may submit such comments by mail, hand delivery, or courier, or you may e-mail them to: cpsc-os@cpsc.gov.

Instructions: All submissions must include the agency name and docket number. CPSC may post all comments without change, including any personal identifiers, contact information, or other personal information provided, to: <https://www.regulations.gov>. Do not submit through this website: confidential business information, trade secret information, or other sensitive or protected information that you do not want to be available to the public. If you wish to submit such information, please submit it according to the instructions for mail/hand delivery/courier/confidential written submissions.

Docket: For access to the docket to read background documents or comments received, go to: <https://www.regulations.gov>, and insert the docket number, CPSC–2019–0025, into the “Search” box, and follow the prompts.

FOR FURTHER INFORMATION CONTACT: Keysha Walker, Compliance Officer, U.S. Consumer Product Safety Commission, 4330 East West Highway, Bethesda, MD 20814; telephone 301-504-6820; email: kwalker@cpsc.gov.

SUPPLEMENTARY INFORMATION:

I. Statutory Authority and Background¹

A. Statutory Authority²

Section 104(b)(1) of the CPSIA requires the Commission to assess the effectiveness of voluntary standards for durable infant or toddler products³ and to adopt mandatory standards for these products. 15 U.S.C. 2056a(b)(1). The mandatory standard must be “substantially the same as” the voluntary standard, or it may be “more stringent than” the voluntary standard, if the Commission determines that more stringent requirements would further reduce the risk of injury associated with the product. *Id.*

Section 104(b)(4)(B) of the CPSIA also specifies the process for when a voluntary standards organization revises a standard that the Commission has incorporated by reference under section 104(b)(1). 15 U.S.C. 2056a(b)(4)(B). First, the voluntary standards organization must notify the Commission of its revised voluntary standard. Once the Commission receives that notification, the Commission may reject or accept the revised voluntary standard. The

¹ On [insert date], the Commission voted (x-x) to publish this direct final rule.

² This direct final rule is based on information and analysis contained in the February 15, 2023, Staff Briefing Package: ASTM’s Notice of a Revised Voluntary Standard for Non-Full Size Baby Cribs (16 CFR Part 1220), available at: [insert URL].

³ Section 104(f)(2)(A) of the CPSIA lists NFS cribs as a durable infant or toddler product. 15 U.S.C. 2056a(f)(2)(A).

Commission may reject the revised standard by notifying the voluntary standards organization, within 90 days of notification, that it has determined that the revised voluntary standard does not improve the safety of the consumer product covered by the standard, and that the Commission is retaining the existing mandatory standard. If the Commission does not take this action to reject the revised voluntary standard, the revised voluntary standard will be considered a consumer product safety standard issued under section 9 of the Consumer Product Safety Act (15 U.S.C. 2058), effective 180 days after the Commission received notification of the revision (or a later date specified by the Commission in the *Federal Register*). 15 U.S.C. 2056a(b)(4)(B).

Additionally, section 104(c) of the CPSIA contains special provisions for rules regarding cribs, including NFS cribs. Sections 104(c)(1) and (2) make the standards the Commission adopts for cribs under section 104(b) of the CPSIA enforceable against a larger class of parties than are ordinarily subject to section 104 rules.⁴ 15 U.S.C. 2056a(c)(1), (2). However, Congress later limited this expanded application of crib standards. Section 104(c)(3) of the CPSIA, added in 2011, limits the application of crib rule updates adopted through the section 104 process to manufacturers or importers of cribs, unless the Commission determines that application to any other person described in section 104(c)(2) is “necessary to protect against an unreasonable risk to health or safety.” 15 U.S.C. 2056a(c)(3); P.L. 112-28, 125 Stat. 273 (Aug. 12, 2011). Based on the lack of incident data related to cords and straps for NFS cribs, as discussed in staff’s

⁴ Section 104(c) prohibits the following parties from manufacturing, selling, contracting to sell or resell, leasing, subletting, offering, providing for use, or otherwise placing in the stream of commerce a crib that is not in compliance with a standard promulgated under section 104(b): “any person that—(A) manufactures, distributes in commerce, or contracts to sell cribs; (B) based on the person’s occupation, holds itself out as having knowledge of skill peculiar to cribs, including child care facilities and family child care homes; (C) is in the business of contracting to sell or resell, lease, sublet, or otherwise place cribs in the stream of commerce; or (D) owns or operates a place of accommodation affecting commerce (as defined in section 4 of the Federal Fire Prevention and Control Act of 1974 (15 U.S.C. § 2203) applied without regard to the phrase ‘not owned by the Federal Government’).” 15 U.S.C. 2056a(c)(2).

briefing package,⁵ the Commission is not making this determination for the current revision to the NFS cribs rule.⁶ Accordingly, as specified in CPSIA section 104(c)(3), this direct final rule applies only to persons that manufacture or import cribs.

B. Safety Standard for NFS Cribs

On December 28, 2010, under section 104 of the CPSIA, the Commission published the first NFS cribs rule that incorporated by reference ASTM F406-10a, *Standard Consumer Safety Specification for Non-Full-Size Cribs/Play Yards*, as the mandatory standard, with modifications to the standard to further reduce the risk of injury. 75 FR 81766, at 81780. That new 16 CFR part 1220 excluded sections of ASTM F406 that apply solely to play yards, which are not covered by part 1220 but are incorporated into a separate rule for play yards, 16 C.F.R. part 1221. *Id.*

Section 1220.1(c)(1) defines a NFS crib as “a bed that is: (i) Designed to provide sleeping accommodations for an infant; (ii) Intended for use in or around the home, for travel, in a child care facility, in a family child care home, in a place of public accommodation affecting commerce and other purposes; (iii) Has an interior length dimension either greater than 139.7 cm (55 in.) or smaller than 126.3 cm (49 3/4 in.), or, an interior width dimension either greater than 77.7 cm (30 5/8 in.) or smaller than 64.3 cm (25 3/8 in.), or both . . . [and] (v) Does not include mesh/net/screen cribs, nonrigidly constructed baby cribs, cradles (both rocker and pendulum types), car beds, baby baskets, and bassinets (also known as junior cribs).” 16 CFR 1220.1(c)(1). The rule further states that NFS cribs include, but are not limited to, portable cribs, crib pens, specialty cribs, undersize cribs, and oversize cribs, as these products are defined in the rule. *Id.*

⁵ See Staff’s Briefing Package at p.6, stating that staff reviewed NFS crib incident data since August 2019 and found no incidents associated with cords or straps.

⁶ CPSC has twice before updated the NFS cribs rule and likewise did not make this determination in either update. 83 FR 26206 (June 6, 2018); 84 FR 56684 (Oct. 23, 2019).

Generally, the NFS cribs rule applies to rigid-sided cribs, while the play yard rule applies to mesh-sided products.

CPSC has twice before updated the NFS cribs rule, adopting ASTM F406-17 in 2018 (83 FR 26206 (June 6, 2018)), and adopting ASTM F406-19 in 2019 (84 FR 56684 (Oct. 23, 2019)). In both cases, CPSC accepted the revised voluntary standard as the mandatory standard for NFS cribs, and updated the incorporation by reference in 16 C.F.R. part 1220 to reflect the revised voluntary standard. In both cases, CPSC also maintained the exceptions listed in section 1220.2(b), which lists sections of the voluntary standard that solely apply to play yards.

On December 5, 2022, ASTM notified the Commission that it had approved and published a newly revised version of the voluntary standard, ASTM F406-22. On December 15, 2022, the Commission published in the *Federal Register* a Notice of Availability, requesting comment on whether the revision improves the safety of NFS baby cribs and/or play yards (87 FR 76614). The public comment period closed on December 29, 2022. CPSC received eight comments, four of which, in supporting the revised voluntary standard, discussed the safety of modified requirements for cords and straps that apply to NFS baby cribs; the remaining comments addressed only play yard safety. Per the statute, the revised voluntary standard will take effect as the new mandatory standard for NFS cribs on June 3, 2023, unless the Commission specifies a later date in the *Federal Register* or notifies ASTM by March 5, 2023, that it has determined the revision does not improve the safety of NFS baby cribs. 15 U.S.C. 2056a(b)(4)(B).

As explained in section II.A of this preamble, ASTM F406-22 contains two substantive revisions to the voluntary standard that improve the safety of NFS cribs. One modification addresses a strangulation hazard by clarifying the requirements and testing of cords and straps on

NFS cribs, and the other modification expands the scope of the voluntary standard to include products that are marketed for play, or sleep, or both. Part II.B of this preamble describes non-substantive clarifications in the revised voluntary standard. Based on staff's evaluation of ASTM F406-22 and consideration of the public comments, the Commission will allow ASTM F406-22 to become the new consumer product safety standard for NFS baby cribs because it improves safety. ASTM F406-22 will become the mandatory consumer product safety standard for NFS cribs on June 3, 2023. 15 U.S.C. 2056a(b)(4)(B). This direct final rule updates 16 CFR part 1220 to incorporate by reference the applicable provisions of the revised voluntary standard, ASTM F406-22, with modifications that maintain the exclusion of requirements that apply solely to play yards.

II. Description of ASTM F406-22 Related to NFS Cribs

The ASTM standard for NFS cribs includes performance requirements, test methods, and requirements for warning labels and instructional literature, to address hazards to infants associated with NFS cribs. The December 2022 revision to the voluntary standard, ASTM F406-22, includes substantive and non-substantive revisions, as described in section II.A and B.

A. Substantive changes in ASTM F406-22

1. Length of Cords/Straps

NFS cribs and their attaching accessories may feature cords/straps intended for various purposes, such as securing and attaching an accessory to the NFS crib's frame. Cords or straps, when either connected or entangled together, may form a loop that presents the risk of strangulation around the neck. To reduce this hazard, ASTM F406-19 specifies requirements for accessories, as defined in section 3.1.1 and 3.1.4 of ASTM F406-19,⁷ that have cords/straps that

⁷ Examples of NFS baby crib accessories include bassinets or changing tables that attach to the top rail of the frame.

can form a loop; the perimeter length of these cords/straps is limited to no more than 16.3 inches.⁸ ASTM F406-22 makes this requirement a general requirement, so that the cord length limit now applies to the whole of in-scope products and not just to the attachment of accessories. ASTM F406-22 limits the maximum permissible perimeter length of a loop such that the standard small head probe, which is based on the head circumference of a 5th percentile 6-month-old child, cannot fit through the loop, thus preventing a strangulation hazard. This change now makes all cords/straps, whether attached to the NFS crib or to an accessory feature, subject to the loop requirement.

ASTM F406-22's loop requirement also addresses connecting cords/straps, such as shown in Figure 1 below. The limit on cord/strap length is intended to prevent a small infant's head, represented by the standard small head probe, from fitting through the loop. ASTM F406-19 limits the free length of any single cord/strap attached to the NFS baby crib to no more than 7.4 inches (section 5.13.1 of ASTM F406-19). Thus, if two straps are attached end-to-end, they cannot form a loop greater than 14.8 inches, which is too small for the standard small head probe. However, products may feature two straps that are attached to the product, separated by a distance L, that can connect to form a loop, as shown in Figure 1. The loop formed by the straps, in addition to the distance L, may exceed the 16.3 inch perimeter length of the standard small head probe. To address the potential for strangulation, ASTM F406-22 states that the length of a loop is in "conjunction with the product," and measures the perimeter length to include the distance L, as shown in Figure 1.

⁸ ASTM F406-22 defines a "cord" as a length of slender flexible material, including monofilaments, rope, woven and twisted cord, plastic and textile tapes, ribbon, and materials commonly called string. ASTM F406-22 defines a "strap" as a piece of flexible material of which the width is significantly greater than the thickness.

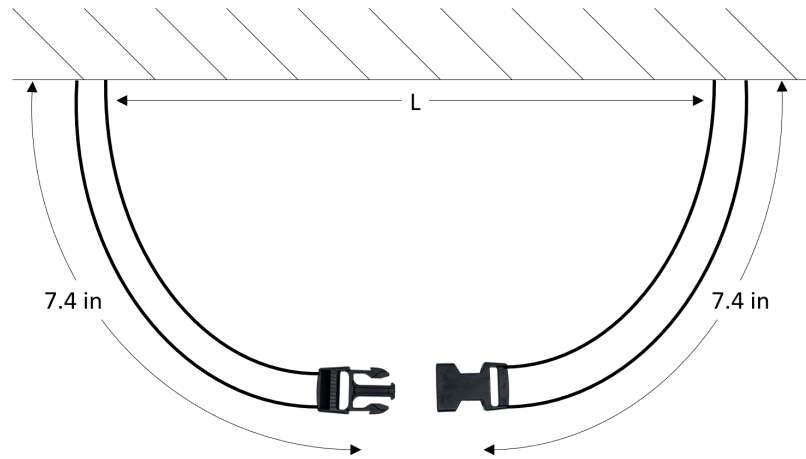

Figure 1. Example of two cords/straps that can form a loop

Adjustable straps, buckles, or other hardware can increase the perimeter of a cord or loop. ASTM F406-19 does not specify testing requirements for such hardware. ASTM F406-22 clarifies and improves the test method in section 8.24.1 to measure the free-hanging length of single cords/straps, now stating: “Using a $\frac{3}{4}$ in. (19 mm) diameter clamping surface (Fig. A1.29), gradually apply a 5 lbf (22 N) force to the end of each cord/strap in its fully-extended configuration.” Testing a strap to “its fully-extended configuration” ensures that a strap with an adjustable length and a sliding buckle is tested to the strap’s maximum length. The update also adds that any hardware attached to the cords/straps, such as buckles, should be included in the length measurement. Lastly, the update specifies that if multiple cords/straps attach to the product in the same location (*i.e.*, distance $L = 0$ in Figure 1 above), they should be treated as separate and measured individually.

Although staff found no incidents related to cords/straps on NFS cribs, the Commission finds that the updates to the cord/strap requirements in ASTM F406-22 are an improvement in safety. The loop requirement that addresses a strangulation risk, and previously was applicable only to cords/straps attached to accessories in ASTM F406-19, is now a general requirement that

applies to all parts of in-scope products. The changes to the free-length measurement test method also improve safety by including adjustable straps, buckles, and other hardware in the length measurement.

2. Scope

Section 1.2 of ASTM F406-19 defines the standard's scope: "This specification covers a framed enclosure with a floor made for the purpose of providing sleeping and playing accommodations for a child who cannot climb out and is less than 35 in. (890 mm) in height." Based on this scope, products that are intended to be used only for play and not for sleep can be excluded from the requirements of the F406-19 standard, and therefore may be hazardous. To cover these products, ASTM F406-22 revises the phrase "sleeping and playing accommodations" to "sleeping or playing accommodations, or both." This, for example, prevents manufacturers from attempting to exempt their products from the standard by specifying the product is exclusively intended for play. This change in ASTM F406-22 is an improvement in safety.

B. Non-substantive changes in ASTM F406-22

1. Accessories Definitions and Entrapment in Accessories Requirements

ASTM F406-22 adds multiple definitions for various types of NFS baby crib accessories, including "play yard/non-full-size crib dependent accessories" (section 3.1.23), "full accessories" (section 3.1.23.1), "full bassinet accessories" (section 3.1.23.2), and "bassinet dependent accessories" (section 3.1.23.3).⁹ ASTM F406-19, in contrast, provides only one general definition for accessories (section 3.1.1). ASTM F406-22 also revises section 5.15 *Entrapment in Accessories* to clarify the types of accessories to which the requirements apply. In ASTM

⁹ "Full accessories" are essentially accessories that fully cover the top opening of the product, "full bassinet accessories" are essentially elevated "full accessories" and "bassinet dependent accessories" are accessories to "full bassinet accessories."

F406-19, the section 5.15 requirements provided a lengthy description stating that these requirements do not apply to accessories that make the non-full-size crib/play yard unusable when the accessory is assembled.¹⁰ ASTM F406-22 now defines these types of accessories as full accessories (section 3.1.23.1) and removes their description from section 5.15, resulting in a shorter, more concise description. Other than these clarifications, the requirements that address entrapment in accessories remain the same. These changes are safety neutral.

2. Mattress Exception for Products Designed Exclusively for Play

ASTM F406-22 moves from a note to a new requirement (section 5.16.1) the language that a mattress is not required to be provided with a product if the product is designed exclusively for play and not for sleep and is intended to be used without a mattress. This change has no effect on safety.

3. Minor Editorial Changes

ASTM F406-22 includes the following editorial changes that have no effect on safety:

- In section 8.26, replaces “play yard” and “non-full-size crib” with “product”;
- Globally changes values given with a tolerance to include units for the nominal value (e.g., 27 ± 2 lbf changed to 27 lbf ± 2 lbf); and
- Globally changes two-dimensional measurements to include units for all values (e.g. 2-by-2in. changed to 2-in. by 2-in.).

C. Public Comments

The Commission requested public comment on how the revisions to ASTM F406-22 affect the safety of NFS cribs. Three commenters (Iron Mountains, Independent Safety Consulting, and the Juvenile Products Manufacturers Association) stated that the addition of a

¹⁰ For example, an accessory such as a bassinet that covers the entire opening of the NFS baby crib will make the lower portion of the product unusable when the accessory is installed.

general requirement for cords/straps that can form a loop improves the safety of NFS cribs. The commenters noted that previously the requirement only restricted the free length of stretched cords/straps to no more than 7.4 inches, but the new requirement is an added protection from the risk of cords/straps that can form a loop. Consumer and Hazardous Product Safety Directorate, Health Canada stated in its comments that the cords/straps requirement aligns with Canada's current regulations for play yards, cribs, cradles, and bassinets. The Commission agrees with the commenters that the addition of a general requirement for cords/straps that can form a loop improves safety. The loop requirement, which was previously only applicable to cords/straps attached to accessories in ASTM F406-19, is now a general requirement that applies to all parts of in-scope products, reducing the risk of strangulation on cords and straps.

D. Assessment of ASTM F406-22

Under CPSIA section 104(b)(4)(B), unless the Commission determines that ASTM's revision to a voluntary standard that is referenced in a mandatory standard "does not improve the safety of the consumer product covered by the standard," the revised voluntary standard becomes the new mandatory standard. The Commission concludes that the substantive changes in ASTM F406-22 related to NFS baby cribs improve the safety of NFS cribs. The requirements addressing loops formed by cords and straps, which were previously only applicable to accessories, are now provided as a general requirement that reduces the strangulation hazard for all cords/straps anywhere on the product. Moreover, changes to the scope of the voluntary standard clarify the coverage of applicable provisions of the standard to all NFS cribs.

III. Incorporation by Reference

Section 1220.2(a) of the direct final rule incorporates by reference ASTM F406-22. The Office of the Federal Register (OFR) has regulations regarding incorporation by reference.

1 CFR part 51. Under these regulations, agencies must discuss, in the preamble to a final rule, ways in which the material the agency incorporates by reference is reasonably available to interested parties, and how interested parties can obtain the material. In addition, the preamble to the final rule must summarize the material. 1 CFR § 51.5(b).

In accordance with the OFR regulations, section II of this preamble, Description of ASTM F406-22 Related to NFS Cribs, summarizes the revised provisions of ASTM F406-22 that the Commission incorporates by reference into 16 CFR part 1220. The standard is reasonably available to interested parties in several ways. Until the direct final rule takes effect, a read-only copy of ASTM F406-22 is available for viewing on ASTM's website at: <https://www.astm.org/CPSC.htm>. Once the rule takes effect, a read-only copy of the standard will be available for viewing on the ASTM website at: <https://www.astm.org/READINGLIBRARY/>. Additionally, interested parties can purchase a copy of ASTM F406-22 from ASTM International, 100 Barr Harbor Drive, P.O. Box C700, West Conshohocken, PA 19428-2959 USA; phone: 610-832-9585; www.astm.org. Finally, interested parties can schedule an appointment to inspect a copy of the standard at CPSC's Office of the Secretary, U.S. Consumer Product Safety Commission, 4330 East West Highway, Bethesda, MD 20814, telephone: 301-504-7479; email: cpsc-os@cpsc.gov.

IV. Testing and Certification

Section 14(a) of the Consumer Product Safety Act (CPSA; 15 U.S.C. 2051-2089) requires manufacturers, including importers, of products subject to a consumer product safety rule under the CPSA, or to a similar rule, ban, standard, or regulation under any other act enforced by the Commission, to certify that the products comply with all applicable CPSC requirements. 15 U.S.C. 2063(a). Such certification must be based on a test of each product, or

on a reasonable testing program, or, for children’s products, on tests of a sufficient number of samples by a third party conformity assessment body accredited by CPSC to test according to the applicable requirements. As noted, standards issued under section 104(b)(1)(B) of the CPSIA are “consumer product safety standards.” Thus, they are subject to the testing and certification requirements of section 14 of the CPSA.

Additionally, because NFS cribs are children’s products, a CPSC-accepted third party conformity assessment body must test samples of the products for compliance with 16 CFR part 1220. Products subject to part 1220 also must be compliant with all other applicable CPSC requirements, such as the lead content requirements in section 101 of the CPSIA,¹¹ the phthalates prohibitions in section 108 of the CPSIA¹² and 16 CFR part 1307, the tracking label requirements in section 14(a)(5) of the CPSA,¹³ and the consumer registration form requirements in section 104(d) of the CPSIA.¹⁴ In accordance with section 14(a)(3)(B)(iv) of the CPSIA, the Commission previously published a notice of requirements (NOR) for accreditation of third party conformity assessment bodies (third party labs) for testing NFS cribs, and codified the requirement at 16 CFR § 1112.15(b)(6).

The modifications to the straps and cord requirements for NFS cribs in ASTM F406-22 use testing requirements that are substantially the same as existing requirements for cords and straps on accessories. Accordingly, the new cord/strap requirements do not require that labs obtain additional test equipment or new training. The Commission considers third party labs that are currently CPSC-accepted for 16 CFR part 1220 to have demonstrated competence to test NFS cribs to the revised ASTM F406-22, as incorporated into part 1220. Accordingly, the

¹¹ 15 U.S.C. 1278a.

¹² 15 U.S.C. 2057c.

¹³ 15 U.S.C. 2063(a)(5).

¹⁴ 15 U.S.C. 2056a(d).

existing accreditations that the Commission has accepted for testing to this standard will cover testing to the revised standard. The existing NOR for the Safety Standard for Non-Full-Size Baby Cribs will remain in place, and CPSC-accepted third party labs are expected to update the scope of their accreditations to reflect the revised NFS cribs standard in the normal course of renewing their accreditations.

V. Direct Final Rule Process

The Commission is issuing this rule as a direct final rule. Although the Administrative Procedure Act (APA; 5 U.S.C. 551-559) generally requires agencies to provide notice of a rule and an opportunity for interested parties to comment on it, section 553 of the APA provides an exception when the agency “for good cause finds” that notice and comment are “impracticable, unnecessary, or contrary to the public interest.” *Id.* 553(b)(B).

The purpose of this direct final rule is to update the reference in the Code of Federal Regulations (CFR) so that it reflects the version of the standard that takes effect by statute. This rule updates the reference in the CFR, but under the terms of the CPSIA, ASTM F406-22 takes effect as the new CPSC standard for NFS cribs, even if the Commission does not issue this rule. Thus, public comments would not lead to substantive changes to the standard or to the effect of the revised standard as a consumer product safety rule under section 104(b) of the CPSIA.

Under these circumstances, notice and comment are unnecessary.

In Recommendation 95-4, the Administrative Conference of the United States (ACUS) endorses direct final rulemaking as an appropriate procedure to expedite rules that are noncontroversial and that are not expected to generate significant adverse comments. *See* 60 FR 43108 (Aug. 18, 1995). ACUS recommends that agencies use the direct final rule process when they act under the “unnecessary” prong of the good cause exemption in 5 U.S.C. 553(b)(B).

Consistent with the ACUS recommendation, the Commission is publishing this rule as a direct final rule, because CPSC does not expect any significant adverse comments. We note that CPSC did not receive any adverse comments based on the Notice of Availability, as reviewed in section II.C of this preamble.

Unless CPSC receives a significant adverse comment within 30 days of this notification, the rule will become effective on June 3, 2023. In accordance with ACUS's recommendation, the Commission considers a significant adverse comment to be "one where the commenter explains why the rule would be inappropriate," including an assertion challenging "the rule's underlying premise or approach," or a claim that the rule "would be ineffective or unacceptable without change." 60 FR 43108, 43111. As noted, this rule updates a reference in the CFR to reflect a change that occurs by statute.

If the Commission receives a significant adverse comment, the Commission will withdraw this direct final rule. Depending on the comment and other circumstances, the Commission may then incorporate the adverse comment into a subsequent direct final rule or publish a notice of proposed rulemaking, providing an opportunity for public comment.

VI. Regulatory Flexibility Act

The Regulatory Flexibility Act (RFA; 5 U.S.C. 601-612) generally requires agencies to review proposed and final rules for their potential economic impact on small entities, including small businesses, and prepare regulatory flexibility analyses. 5 U.S.C. 603, 604. The RFA applies to any rule that is subject to notice and comment procedures under section 553 of the APA. *Id.* As discussed in section V of this preamble regarding the Direct Final Rule Process, the Commission has determined that notice and the opportunity to comment are unnecessary for this rule. Therefore, the RFA does not apply. The Commission also notes the limited nature of

this document, which updates the incorporation by reference to reflect the mandatory CPSC standard that takes effect under section 104 of the CPSIA.

VII. Paperwork Reduction Act

The current mandatory standard for NFS cribs includes requirements for marking, labeling, and instructional literature that constitute a “collection of information,” as defined in the Paperwork Reduction Act (PRA; 44 U.S.C. 3501-3521). The revised mandatory standard for NFS cribs does not alter these requirements. The Commission took the steps required by the PRA for information collections when it adopted 16 CFR part 1220, including obtaining approval and a control number. Because the information collection is unchanged, the revision does not affect the information collection requirements or approval related to the standard.

VIII. Environmental Considerations

The Commission’s regulations provide for a categorical exclusion from any requirement to prepare an environmental assessment or an environmental impact statement where they “have little or no potential for affecting the human environment.” 16 CFR 1021.5(c)(2). This rule falls within the categorical exclusion, so no environmental assessment or environmental impact statement is required.

IX. Preemption

Section 26(a) of the CPSA provides that where a consumer product safety standard is in effect and applies to a product, no state or political subdivision of a state may either establish or continue in effect a requirement dealing with the same risk of injury unless the state requirement is identical to the Federal standard. 15 U.S.C. 2075(a). Section 26(c) of the CPSA also provides that states or political subdivisions of states may apply to CPSC for an exemption from this preemption under certain circumstances. Section 104(b) of the CPSIA deems rules issued under

that provision “consumer product safety standards.” Therefore, once a rule issued under section 104 of the CPSIA takes effect, it will preempt in accordance with section 26(a) of the CPSA.

X. Effective Date

Under the procedure set forth in section 104(b)(4)(B) of the CPSIA, when a voluntary standards organization revises a standard that the Commission adopted as a mandatory standard, the revision becomes the CPSC standard 180 days after notification to the Commission, unless the Commission determines that the revision does not improve the safety of the product, or the Commission sets a later date in the *Federal Register*. 15 U.S.C. 2056a(b)(4)(B). The Commission is taking neither of those actions with respect to the revised standard for NFS cribs. Therefore, ASTM F406-22 automatically will take effect as the new mandatory standard for NFS cribs on June 3, 2023, 180 days after the Commission received notice of the revision. As a direct final rule, unless the Commission receives a significant adverse comment within 30 days of this notice, the rule will become effective on June 3, 2023.

XI. Congressional Review Act

The Congressional Review Act (CRA; 5 U.S.C. 801-808) states that before a rule may take effect, the agency issuing the rule must submit the rule, and certain related information, to each House of Congress and the Comptroller General. 5 U.S.C. 801(a)(1). The CRA submission must indicate whether the rule is a “major rule.” The CRA states that the Office of Information and Regulatory Affairs (OIRA) determines whether a rule qualifies as a “major rule.”

Pursuant to the CRA, OIRA has determined that this rule does not qualify as a “major rule,” as defined in 5 U.S.C. 804(2). To comply with the CRA, CPSC will submit the required information to each House of Congress and the Comptroller General.

List of Subjects in 16 CFR Part 1220

Consumer protection, Imports, Incorporation by reference, Infants and children, Labeling, Law enforcement, Safety, and Toys.

For the reasons discussed in the preamble, the Commission amends 16 CFR chapter II as follows:

PART 1220 – SAFETY STANDARD FOR NON-FULL-SIZE BABY CRIBS

1. Revise the authority citation for part 1220 to read as follows:

Authority: 15 U.S.C. 2051 Notes; 15 U.S.C. 2056a.

2. Amend 1220.2 by revising paragraph 1220.2 to read as follows:

§ 1220.2 Requirements for non-full-size baby cribs.

(a) Except as provided in paragraph (b) of this section, each non-full-size baby crib shall comply with all applicable provisions of ASTM F406-22, *Standard Consumer Safety Specification for Non-Full-Size Baby Cribs/Play Yards*, approved on October 1, 2022. The Director of the Federal Register approves this incorporation by reference in accordance with 5 U.S.C. 552(a) and 1 CFR part 51. A free, read-only copy of the standard is available for viewing on the ASTM website at <https://www.astm.org/READINGLIBRARY/>. You may also obtain a copy from ASTM International, 100 Barr Harbor Drive, PO Box C700, West Conshohocken, PA 19428-2959; phone: (610) 832-9585; www.astm.org. You may inspect a copy at the Office of the Secretary, U.S. Consumer Product Safety Commission, 4330 East West Highway, Bethesda, MD 20814, telephone (301) 504-7479, email: cpsc-os@cpsc.gov, or at the National Archives and Records Administration (NARA). For information on the availability of this material at NARA, email fr.inspection@nara.gov, or go to: www.archives.gov/federal-register/cfr/ibr-locations.html.

(b) Comply with the ASTM F406-22 standard with the following exclusions:

OS 22
DRAFT

- (1) Do not comply with sections 5.6.2 through 5.6.2.4 of ASTM F406-22.
- (2) Do not comply with section 5.16.2 through 5.16.2.2 of ASTM F406-22.
- (3) Do not comply with sections 5.19 through 5.19.2.2 of ASTM F406-22.
- (4) Do not comply with section 7, *Performance Requirements for Mesh/Fabric Products*, of ASTM F406-22.
- (5) Do not comply with sections 8.11 through 8.11.2.4 of ASTM F406-22.
- (6) Do not comply with sections 8.12 through 8.12.2.2 of ASTM F406-22.
- (7) Do not comply with sections 8.14 through 8.14.2 of ASTM F406-22.
- (8) Do not comply with sections 8.15 through 8.15.3.3 of ASTM F406-22.
- (9) Do not comply with section 8.16 through 8.16.3 of ASTM F406-22.
- (10) Do not comply with sections 8.28 through 8.28.3.2 of ASTM F406-22.
- (11) Do not comply with sections 8.29 through 8.29.3 of ASTM F406-22.
- (12) Do not comply with sections 8.30 through 8.30.5 of ASTM F406-22.
- (13) Do not comply with sections 8.31 through 8.31.9 of ASTM F406-22.
- (14) Do not comply with sections 9.3.2 through 9.3.2.4 of ASTM F406-22.

Alberta E. Mills,
Secretary,
Consumer Product Safety Commission.



Memorandum

Date: February 15, 2023

TO: The Commission
Alberta E. Mills, Secretary

THROUGH: Austin C. Schlick, General Counsel
Jason K. Levine, Executive Director
DeWane Ray, Deputy Executive Director for Safety Operations

FROM: Duane E. Boniface, Assistant Executive Director
Office of Hazard Identification and Reduction

Frederick DeGrano, Mechanical Engineer
Division of Mechanical and Combustion Engineering
Directorate for Engineering Sciences

SUBJECT: ASTM's Notice of a Revised Voluntary Standard for Non-Full Size Baby Cribs (16 CFR Part 1220)

I. Introduction/Background

On December 28, 2010, the U.S. Consumer Product Safety Commission (CPSC or Commission) published a final rule issuing a mandatory standard for non-full-size (NFS) baby cribs. The 2010 rule incorporated by reference ASTM F406-10a, *Standard Consumer Safety Specification for Non-Full-Size Baby Cribs/Play Yards*, with modifications that exclude those sections of ASTM F406-10a that apply to play yards exclusively (75 FR 81766). The Commission promulgated this final rule under section 104 of the Consumer Product Safety Improvement Act (CPSIA) of 2008, and the rule is codified in 16 CFR part 1220, *Safety Standard for Non-Full-Size Baby Cribs*. This mandatory standard for NFS baby cribs does not apply to play yards and, as noted, excludes sections of ASTM F406 that relate only to play yards.

Since the final rule for NFS baby cribs was issued, the Commission has twice issued direct final rules to update the mandatory standard for NFS baby cribs after ASTM notified the Commission of updates to the NFS baby cribs standard:

- On June 6, 2018, the Commission published a final rule to amend part 1220 to reflect incorporation by reference of ASTM F406-17 (83 FR 26206).
- On October 23, 2019, the Commission published a direct final rule to update part 1220 to reflect incorporation by reference of ASTM F406-19 (84 FR 56684).

**U.S. Consumer Product
Safety Commission**

4330 East-West Highway
Bethesda, MD 20814

cpsc.gov

**National Product Testing
& Evaluation Center**

5 Research Place
Rockville, MD 20850

This memorandum was prepared by the CPSC staff. It has not been reviewed or approved by, and may not necessarily reflect the views of, the Commission.

On December 5, 2022, ASTM notified the Commission that it had approved and published another revised version of the voluntary standard, ASTM F406-22. On December 15, 2022, the Commission published in the *Federal Register* a Notice of Availability, requesting comment on whether the revision improves the safety of NFS baby cribs (87 FR 76614). The public comment period closed on December 29, 2022, and CPSC received eight comments, three of which discussed safety related to NFS baby cribs. The remaining comments addressed only play yard safety.

The revised standard will take effect as the new mandatory standard on June 3, 2023, unless the Commission specifies a later date in the *Federal Register* or notifies ASTM by March 5, 2023, that it has determined the revision does not improve the safety of NFS baby cribs (see 15 U.S.C. 2056a(b)(4)(B)).

This memorandum outlines the differences between ASTM F406-19 and F406-22, specifically for sections that are applicable to NFS baby cribs and the mandatory *Safety Standard for Non-Full-Size Baby Cribs*, and it assesses the impact of the revised voluntary standard on the safety of NFS baby cribs. Based on staff's evaluation of the revised voluntary standard, staff recommends that the Commission allow ASTM F406-22 to be the new consumer product safety standard for NFS baby cribs because it improves safety.

II. Discussion

The following summarizes and discusses the changes included in the latest revision ASTM F406-22, *Standard Consumer Safety Specification for Non-Full-Size Baby Cribs/Play Yards*. This version is an update to the previous version, ASTM F406-19, which is incorporated by reference, with modification, by CPSC's current mandatory *Safety Standard for Non-Full-Size Baby Cribs*, into 16 CFR part 1220.

A. Substantive changes in ASTM F406-22

1. Length of Cords/Straps

NFS baby cribs and their attaching accessories may feature cords/straps intended for various purposes, such as securing an attaching an accessory to the crib's frame. Cords or straps, when either connected or entangled together, may form a loop through which an infant may crawl, presenting the risk of strangulation around the neck. To reduce this hazard, ASTM F406-19 specifies requirements for those accessories, as defined in section 3.1.1 and 3.1.4 of ASTM F406-19,¹ that have cords/straps that can form a loop; under this element of ASTM F406-19, the perimeter length of the accessory cords/straps must not be more than 16.3 inches.² ASTM F406-22 adds this as a general requirement that now applies to the whole of in-scope products and not just the attaching accessories. This maximum permissible perimeter length of loop is too small for the standard small head probe, based on a 5th percentile 6-month-old child from

¹ Examples of NFS baby crib accessories include bassinets or changing tables that attach to the top rail of the frame.

² ASTM F406-22 defines a "cord" as a length of slender flexible material, including monofilaments, rope, woven and twisted cord, plastic and textile tapes, ribbon, and materials commonly called string. ASTM F406-22 defines a "strap" as a piece of flexible material of which the width is significantly greater than the thickness.

fitting through the loop, and the length restriction is intended to prevent strangulation hazards. This change now makes all cords/straps, whether attached to the NFS baby crib or to an accessory feature, subject to the loop requirement.

ASTM F406-22's loop requirement addresses cords/straps, such as shown in Figure 1 below. ASTM F406-19 limits the free length of any single cord/strap attached to the NFS baby crib to no more than 7.4 inches (section 5.13.1 of ASTM F406-19). Thus, if two straps are attached end-to-end, they cannot form a loop greater than 14.8 inches, which is too small for the standard small head probe; this prevents a small infant's head from fitting through the loop. However, as illustrated in Figure 4, products may feature two straps that are attached to the product, separated by a distance L , that can connect to form a loop. Therefore, for a product that complies with ASTM F406-19, the loop formed by the straps in addition to the distance L may exceed the perimeter length of the standard small head probe of 16.3 inches. ASTM F406-22's loop requirement states that the length of the loop is in "conjunction with the product"; thus, the perimeter measurement includes the distance L in the example below. This revision reduces the risk of strangulation with these types of cords/straps.

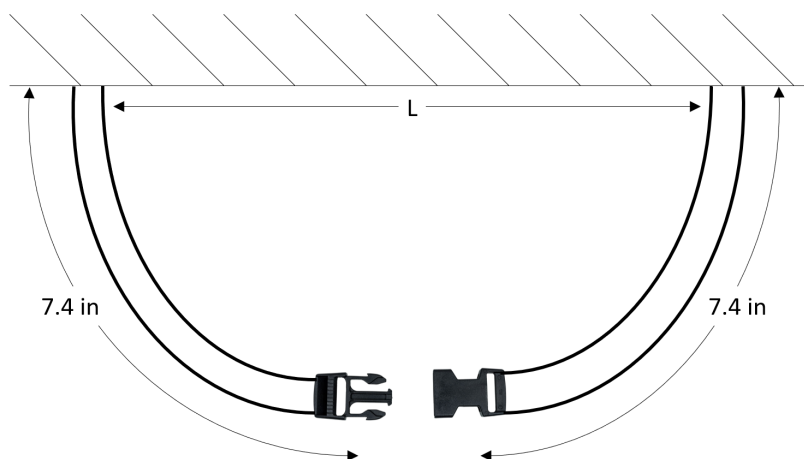

Figure 1. Example of two cords/straps that can form a loop

ASTM F406-22 also modifies the test method to measure the free-hanging length of single cords/straps section 8.24.1. The requirement now states: "Using a $\frac{3}{4}$ in. (19 mm) diameter clamping surface (Fig. A1.29), gradually apply a 5 lbf (22 N) force to the end of each cord/strap in its fully-extended configuration." The added phrase "in its fully-extended configuration" accounts for straps that have adjustable lengths with a sliding buckle, making sure they are extended to the strap's maximum length. The update also adds that any hardware attached to the cords/straps, such as buckles, should be included in the length measurement. ASTM F406-19 does not specify that hardware should be included. Lastly, the update specifies that if multiple cords/straps attach to the product in the same location (*i.e.*, distance $L = 0$ in Figure 1 above), they should be treated as separate and measured individually.

Staff concludes that the updates to the cord/strap requirements in ASTM F406-22 are, in themselves, an improvement in safety. The loop requirement that previously was applicable only to cords/straps attached to accessories in ASTM F406-19, is now a general requirement that applies to all parts of in-scope products. The changes to the free-length measurement test method provide additional clarification to the test method in ASTM F406-19 by adding specificity on length of adjustable cords/straps and by including hardware in the measurement.

2. Scope

Section 1.2 of ASTM F406-19 defines the standard's scope: "This specification covers a framed enclosure with a floor made for the purpose of providing sleeping and playing accommodations for a child who cannot climb out and is less than 35 in. (890 mm) in height." Based on this scope, products that are intended to be used for play only, and not for sleep, can be excluded from the requirements of the F406-19 standard. ASTM F406-22 revises the phrase ". . . sleeping and playing accommodations . . ." to ". . . sleeping or playing accommodations, or both . . ." to cover these types of products. This, for example, prevents manufacturers from exempting their products from the standard by specifying the product is exclusively intended for play. Staff considers this change in ASTM F406-22 to be an improvement in safety because it brings additional products within the scope of the ASTM F406 requirements that are intended to address multiple hazards.

B. Non-substantive changes in ASTM F406-22

1. Accessories Definitions and Entrapment in Accessories Requirements

ASTM F406-22 adds multiple definitions for various types of NFS baby crib accessories, including "play yard/non-full-size crib dependent accessories" (section 3.1.23), "full accessories" (section 3.1.23.1), "full bassinet accessories" (section 3.1.23.2), and "bassinet dependent accessories" (section 3.1.23.3).³ ASTM F406-19, in contrast, provided only one general definition for accessories (section 3.1.1). ASTM F406-22 also revises Section 5.15 *Entrapment in Accessories* to improve clarity on the types of accessories to which the requirements apply. In ASTM F406-19, the section 5.15 requirements provided a lengthy description stating that these requirements do not apply to accessories that make the non-full-size crib/play yard unusable when the accessory is assembled.⁴ ASTM F406-22 now defines these types of accessories as full accessories (section 3.1.23.1) and removes their description from section 5.15, resulting in a shorter, more concise description. Other than these clarifications, the requirements that address entrapment in accessories remain the same. Staff concludes these changes have no effect on safety.

³ "Full accessories" are essentially accessories that fully cover the top opening of the product, "full bassinet accessories" are essentially elevated "full accessories" and "bassinet dependent accessories" are accessories to "full bassinet accessories."

⁴ For example, an accessory such as a bassinet that covers the entire opening of the NFS baby crib will make the lower portion of the product unusable when the accessory is installed.

2. Mattress Exception for Products Designed Exclusively for Play

ASTM F406-22 moves from a note to a new requirement (section 5.16.1) the language that a mattress is not required to be provided with a product if the product is designed exclusively for play and not for sleep and is intended to be used without a mattress. Staff concludes this change has no effect on safety.

3. Minor Editorial Changes

ASTM F406-22 includes the following editorial changes:

- In section 8.26, replaces “play yard” and “non-full-size crib” with “product”;
- Globally changes values given with a tolerance to include units for the nominal value (e.g., 27 ± 2 lbf changed to $27 \text{ lbf} \pm 2 \text{ lbf}$); and
- Globally changes two-dimensional measurements to include units for all values (e.g. 2-by-2in. changed to 2-in. by 2-in.).

Staff concludes these editorial changes have no effect on safety.

III. Public Comments

The Commission requested public comment on the effect the entire set of revisions to F406 will have on the safety of consumer products covered by the standard, meaning play yards as well as NFS baby cribs. CPSC received eight public comments, three of which discussed changes related to NFS baby cribs (rather than just play yards). The discussion below summarizes and responds to the comments regarding NFS baby cribs.

Comment

All three commenters (Iron Mountains, Independent Safety Consulting, and the Juvenile Products Manufacturers Association) stated that the addition of a general requirement for cords/straps that can form a loop improves safety. The commenters noted that previously, the requirement only restricted the free length of stretched cords/straps to no more than 7.4 inches, but the new requirement is an added protection from the risk of cords/straps that can form a loop. Health Canada stated that the cords/straps requirement aligns with Canada’s current regulations for play yards, cribs, cradles, and bassinets.

Response

Staff agrees with the commenters that the addition of a general requirement for cords/straps that can form a loop improves safety. The loop requirement, which was previously only applicable to cords/straps attached to accessories in ASTM F406-19, is now a general requirement that applies to all parts of in-scope products.

IV. Staff’s Assessment of the Revised Standard

Under CPSIA section 104(b)(4)(B), unless the Commission timely determines that ASTM’s revision to a voluntary standard that is referenced in a mandatory standard “does not improve

the safety of the consumer product covered by the standard,” the revised voluntary standard becomes the new mandatory standard. Staff concludes that the substantive changes in ASTM F406-22 related to NFS baby cribs are an increase in safety. The requirements addressing loops formed by cords and straps, which were previously only applicable to accessories, are now provided as a general requirement that reduces the suffocation hazard for all cords/straps anywhere on the product.

V. CPSIA Provisions for Cribs

The CPSIA specifies provisions for cribs in section 104(c), which states that the standards for full-size and NFS cribs would apply to persons (such as those owning or operating childcare facilities and places of public accommodation) in addition to manufacturers and importers, the persons usually subject to consumer product safety rules.⁵ The crib standards that the Commission issued in 2010 followed this statutory direction. In 2011, however, Congress again specifically addressed the applicability of crib standards, stating that any revision of the crib standards after their initial promulgation “shall apply only to a person that manufactures or imports cribs,” unless the Commission determines that application to any others covered by the initial crib standards is “necessary to protect against an unreasonable risk to health or safety.” If the Commission does apply the revised crib standard to additional persons, it must provide at least 12 months for those persons to come into compliance. Staff’s review of incident data since August 2019 has not identified any strangulation incidents involving cords/straps on NFS baby cribs; therefore, staff does not recommend that the Commission expand the applicability of the revised crib standard.

VI. Effect of the Changes on Third-Party Testing

In accordance with section 14(a) of the CPSA, the Commission has previously published a notice of requirements (NOR) which provided the criteria and process for the Commission’s acceptance of accreditation of third-party conformity assessment bodies for testing NFS cribs to 16 CFR part 1220 (which incorporated ASTM F406-10a with modifications). The NORs are listed in the Commission’s rule, “Requirements Pertaining to Third Party Conformity Assessment Bodies,” 16 CFR part 1112. As discussed above, the revisions to the cords and straps requirements for NFS cribs in ASTM F406-22 have testing requirements that are similar to existing requirements, and do not require that labs obtain additional test equipment or new training. Therefore, staff recommends that the Commission consider third party labs that are currently CPSC-accepted for 16 CFR part 1220 to have demonstrated competence to test NFS cribs to the revised ASTM F406-22, as incorporated into part 1220. In this case, the existing NOR for this standard will remain in place, and CPSC-accepted third party conformity

⁵ Under section 104(c) of the CPSIA, the initial crib standards applied to: “any person that –
 (A) manufactures, distributes in commerce, or contracts to sell cribs;
 (B) based on the person’s occupation, holds itself out as having knowledge of skill peculiar to cribs, including child care facilities and family child care homes;
 (C) is in the business of contracting to sell or resell, lease, sublet, or otherwise place cribs in the stream of commerce; or
 (D) owns or operates a place of accommodation affecting commerce (as defined in section 4 of the Federal Fire Prevention and Control Act of 1974 (15 U.S.C. 2203) applied without regard to the phrase ‘not owned by the Federal Government’).

assessment bodies would be expected to update the scope of the testing laboratories' accreditation to reflect the revised standard in the normal course of renewing their accreditation. If the Commission incorporates ASTM F406-22 into its rules pursuant to CPSIA section 104, CPSC staff will notify all CPSC-accepted labs by direct email and will provide links to the Federal Register notice to explain the changes to the standard and the effective date.

VII. Recommendation

Pursuant to section 104(b)(4)(B) of the CPSIA, because CPSC staff assesses that ASTM's revised voluntary standard increases the safety of NFS baby cribs, staff recommends that the Commission accept ASTM F406-22 as a consumer product safety standard issued by the Commission effective 180 days after notice of the revision. Accordingly, staff recommends updating the incorporation by reference in the mandatory rule for NFS baby cribs, 16 CFR part 1220, to reflect the requirements in ASTM F406-22 applicable to these products.