

U.S. Consumer Product Safety Commission



Lithium-Ion Battery Safety Standards for Consumer Product Import into the United States

May 16, 2017
Shenzhen, China

This presentation was prepared by CPSC staff, has not been reviewed or approved by,
and may not reflect the views of, the Commission.

Outline

Part 1: Data

- Basics on CPSC Databases
- Battery Incident Data
- Recalls

Part 2: Lithium-Ion Battery-Powered Product Case Studies

- No Product Standard (Before UL 2272) – Electric Scooters/Hoverboards
- Well-Developed Standards – Cell Phones and Laptops
- Lessons Learned – System Safety



Outline

Part 1: Data

- Basics on CPSC Databases
 - Electrical Product Safety
 - CPSC Risk Mitigation
- Battery Incident Data
- Recalls

Part 2: Lithium-Ion Battery-Powered Product Case Studies

- No Product Standard (Before UL 2272) – Electric Scooters/Hoverboards
- Well-Developed Standards – Cell Phones and Laptops
- Lessons Learned – System Safety



Electrical Product Hazards

- Electricity is a powerful, useful energy source that is potentially hazardous.
- Product failures or misuse can cause fires, electric shock, thermal burns (from exposure to hot surfaces), chemical burns (from batteries), injuries (lacerations from moving parts) or loss of critical function (a smoke alarm not signaling a fire).
- Equipment that generates, distributes, or uses electrical energy should be compliant with standards and installed according to applicable electrical codes to mitigate safety risks.



Electrical Product Hazards in U.S. Homes

CPSC staff est. average from 2011 to 2013:

- 43,400 structure fires from electrical equipment per year
 - 420 deaths, 3,000 injuries, & \$1.17 billion in property losses
 - Fires attributed mostly to:
 - Electric cooking equipment
 - Electrical distribution systems
 - Electric heating and cooling equipment

- From 2007 to 2009: est. average 70 product-related electrocutions per year



Electrical Product Hazard Prevention Strategies

CPSC staff promotes electrical safety through a multipronged approach

- Supporting improvements to voluntary standards/codes
- Disseminating safety information to consumers
- Creating and enforcing technical regulations and bans
- Recalling products with defects - identifying hazards through surveillance activities



Voluntary Consensus Standards

- Electrical product safety heavily relies on compliance with voluntary industry-consensus standards.
 - Most electrical product safety standards have been developed and maintained under the auspices of Underwriters Laboratories (UL). Other standards developers for electrical product safety include the Institute of Electrical and Electronics Engineers (IEEE) and the National Electrical Manufacturers Association (NEMA)



Technical Regulations

Regulatory process can be started by vote of the Commission or by a petition from an interested party

CPSC statutes specify that voluntary standards should be relied upon. However, a regulation may be issued if:

the current voluntary standard does not adequately reduce the risk

or

there is not substantial compliance.



Technical Regulations – “15J” Rules

- Takes an “observable characteristic” from a consumer product which has substantial compliance with the voluntary standard to reduce the hazard.
- Noncompliance results in automatic status as a “substantial product hazard.”
- Products that don’t comply with a 15J Rule won’t be allowed into the United States



Electrical Product Technical Regulations

- 16 CFR 1505 – Requirement for electrically operated toys or other electrically-operated articles intended for use by children



- 16 CFR 1204 - Safety Standard for Omnidirectional Citizens Band Base Station Antennas

15(j) Rule

- 16 CFR 1120.3(a) – Household and commercial handheld hair dryers must have an integral immersion protection circuit interrupter plug (as per UL 859 and UL 1727)
- 16 CFR 1120.3(c) – Seasonal and decorative lighting products must meet the minimum wire size requirements of UL 588, have sufficient strain relief and include integral overcurrent protection.
- 16 CFR 1120.3(d) – Extension Cords must meet the minimum wire size requirements of UL 817, have sufficient strain relief, be properly polarized and indoor-use cords must have outlet covers while outdoor-use cords must be jacketed.



Seasonal and Decorative Lighting Products



Lighting Products - Outside the Scope



Lighting Products -Three Observables

- Overcurrent Protection (a.k.a. fuse or fuses)
- Wire Size
- Strain relief



Extension Cords



Extension Cords - Outside the Scope



Extension Cords – Five Observables

- Minimum wire size
- Sufficient strain relief
- Proper polarization
- Proper continuity
- Protective feature (outlet covers or jacketed cord)



Voluntary Consensus Standards Third Party Certification

- CPSC's regulations do not require third party certification for electrical products (except for electric toys), but there is a high rate of voluntary compliance.
 - Many retailers will only sell electrical products if they have been third party certified.
 - Some states and municipalities require certification for all electrical products to be sold in those jurisdictions.
 - The Occupational Safety and Health Administration (OSHA) requires certification for electrical products used in the workplace.



CPSC staff strongly recommends that manufacturers or exporters/importers seek third party certification for their electrical products as a means of hazard mitigation.



Voluntary Consensus Standards

- Staff actively participates in the process of maintaining the standards by addressing emerging hazards through development and adoption of new or modified requirements.
- This is an ongoing process that begins with reviewing incident information from CPSC's data collection systems.



CPSC Data Collection Systems

Staff learns about product-related incidents from five databases

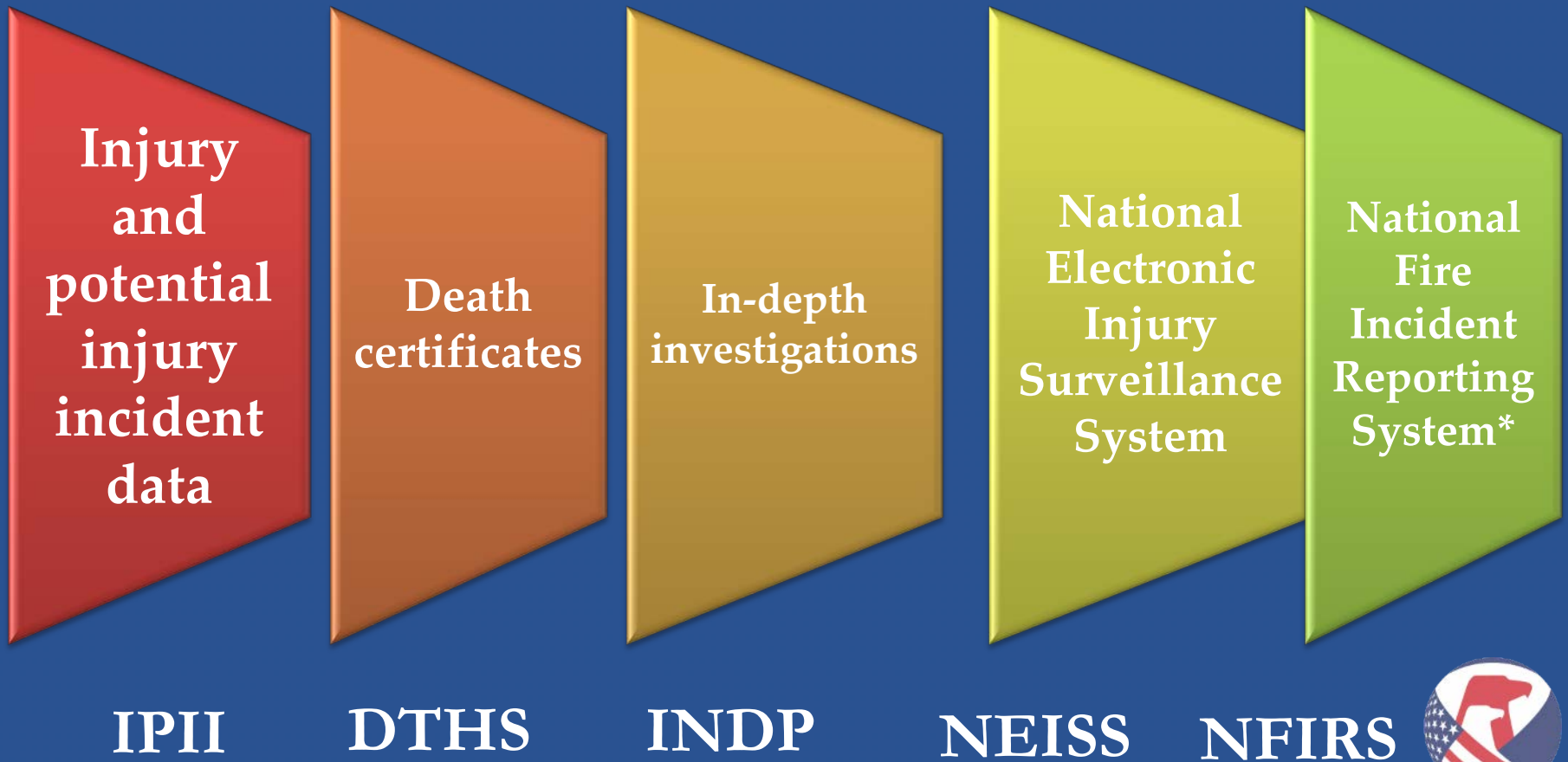

*NFIRS is operated by the United States Fire Administration



INJURY AND POTENTIAL INJURY INCIDENT

Medical Examiners and Coroners Alert Program (MECAP)	News Clips	Hotline Calls	Internet Reports	Compliance Reports	Federal and State Agency Referrals	Other Reports
------------------------------------------------------	------------	---------------	------------------	--------------------	------------------------------------	---------------



[Report An Unsafe Product](#) [Business Register & Respond](#) [Search Recalls & Reports](#) [About](#) [Questions](#)

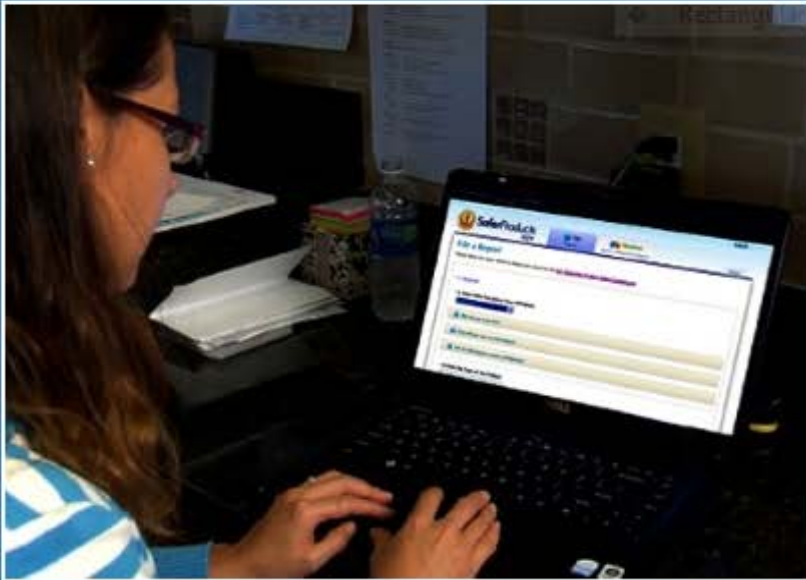

Welcome Consumers

Report your unsafe product on SaferProducts.gov. Tell CPSC. Then others will know.

[Get Started](#)

[Report An Unsafe Product](#)

[Business Sign In](#)

Search

Recalls & Reports

GO

[Advanced Search](#)

Most Searched

[Appliances](#)

[Cribs](#)

[High Chairs](#)

20



DEATH CERTIFICATES DATABASE (DTHS)

- Contracts with 50 states
- Purchase approximately 8,000 per year
- Time lag
- Daily review
- Analytical use



IN DEPTH INVESTIGATIONS DATABASE (INDP)

- Field Investigations
 - On site
 - Local-level collaboration
 - Medical examiner
 - Police
 - Fire
 - Sample collection opportunity
- Telephone Interviews



NATIONAL ELECTRONIC INJURY SURVEILLANCE SYSTEM (NEISS)

- National sample
 - Data collected from approximately 100 hospital emergency rooms around the country
 - Data weighted to provide consumer injury estimates nationwide
- Multilevel system
 - About 395,000 consumer product-related injury reports annually
 - About 300,000 other incident reports annually
- Data submitted daily by hospital coders
- Data available from 1980 to present



MAP OF NEISS HOSPITAL LOCATIONS

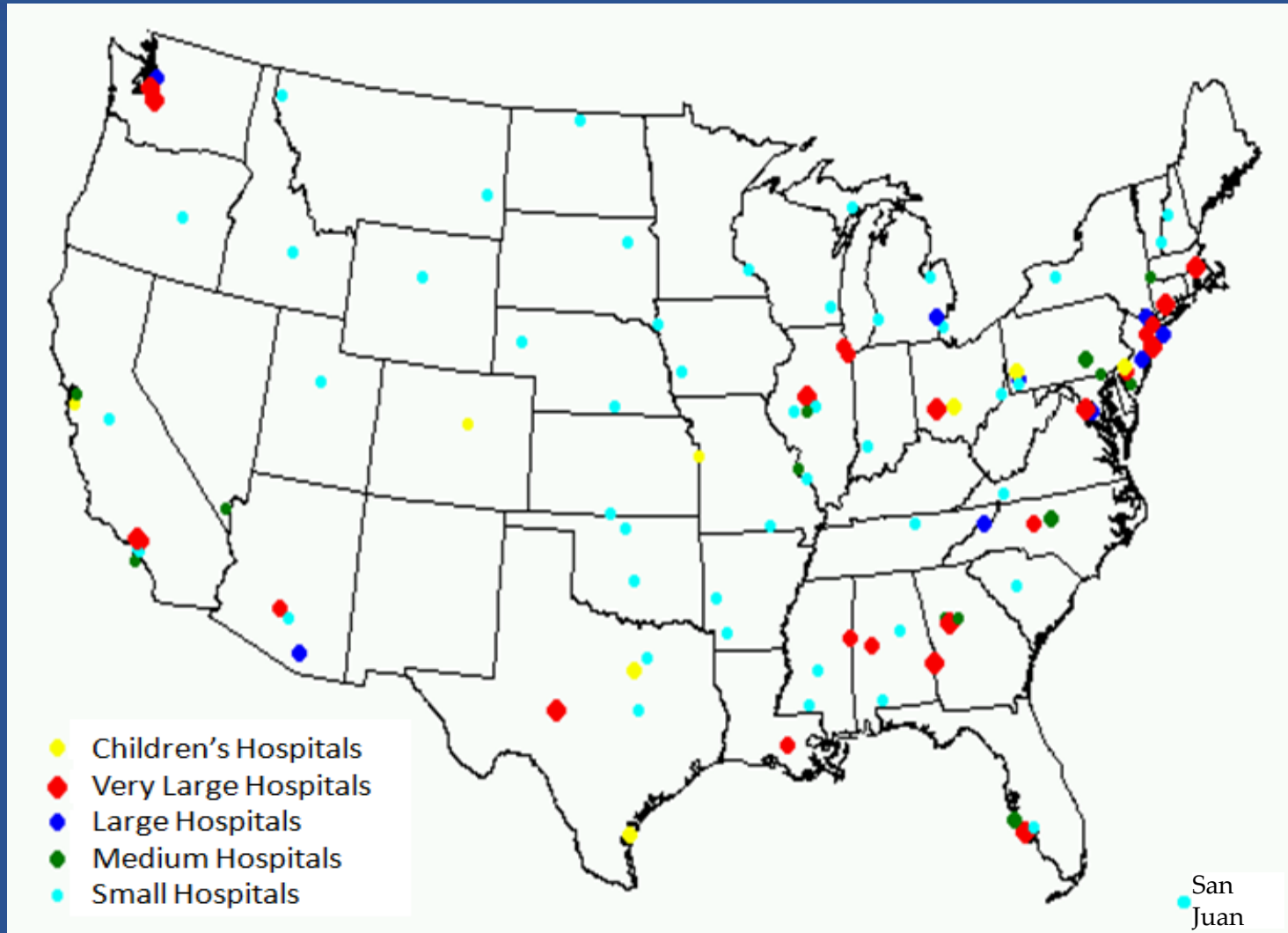

Why Emergency Department Data?

- Large numbers of injuries are treated.

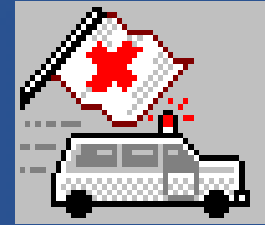

- Data are already being captured in ED record on these cases.

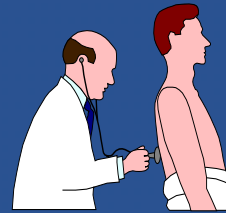

- Hospitals have been very cooperative in supporting CPSC data collection activities.

- The information is timely.



NEISS Surveillance Variables

- Treatment date
- Case number
- Age
- Sex
- Injury diagnosis
- Body part injured
- Disposition from ED
- Products involved (2)
- Locale
- Type/work-related
- Fire dept. involvement
- Intent
- Race/ethnicity
- Narrative (2 lines)



MORE INFORMATION?

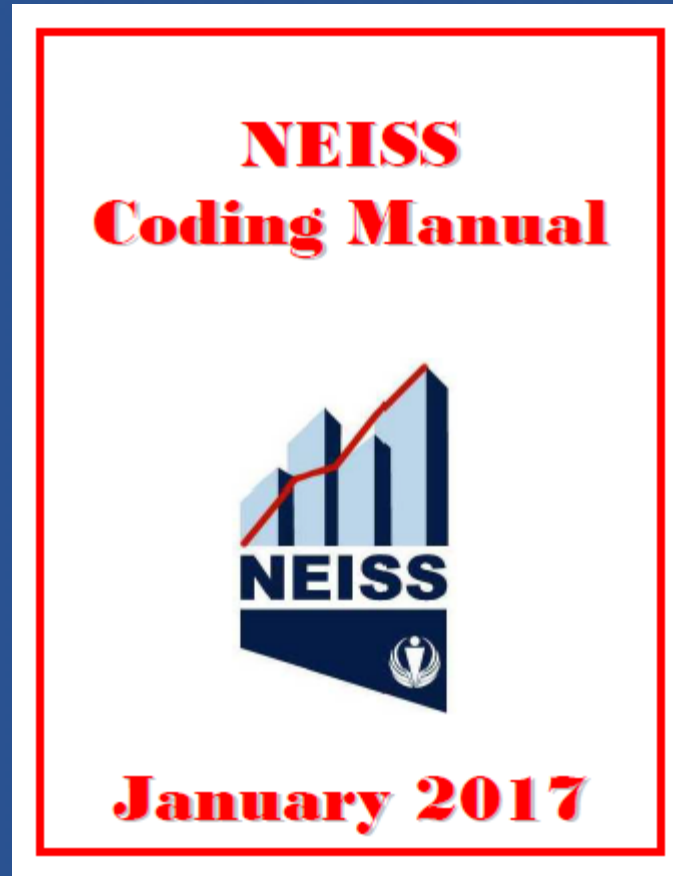

<https://www.cpsc.gov/s3fs-public/2017NEISSCodingManualCPSCOnlyNontrauma.pdf>



Integrated Teams

- Chemical
- Children
- Combustion
- Electrical
- Fire
- Seniors and Mechanical



HAZARD IDENTIFICATION

Integrated teams of experts review incidents and/or physical samples to:

- Identify hazards described
- Examine chain of events
- Review circumstances of incident, modes of failure
- Identify incident hazard patterns
- Screen for trends and emerging hazards
- Determine compliance with standards



Voluntary Standards - Staff Participation

Process for improving standards

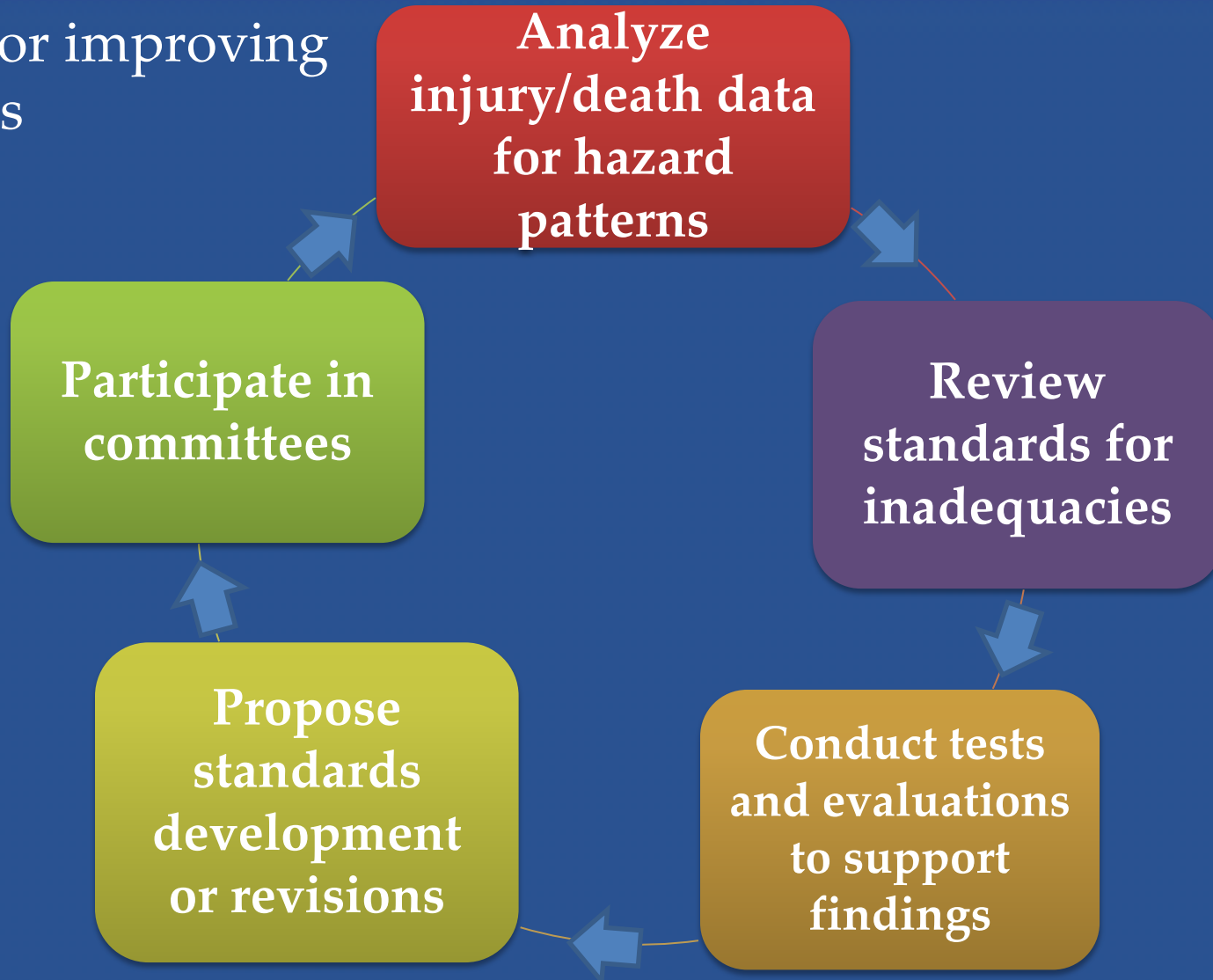

Responsibility to Comply

- Compliance with applicable regulations, standards, and the *NEC* are highly effective ways to mitigate hazards from equipment that generates, distributes, or uses electrical energy.



- Importers, although reliant on foreign producers, are directly responsible for the safety of products they bring into the United States.



Responsibility to Comply

Manufacturers and importers should follow best practices to ensure that their products do not pose substantial risk of injury and need to be recalled.

- Comply with consensus standards and technical regulations
- Obtain third party certification for products
- Maintain quality and configuration control
 - Assess impact of material or component substitutions



Summary

Electrical safety requires diligence from producer to user.

- Electrical products should:
 - comply with relevant CPSC Technical Regulations
 - be designed and manufactured in accordance with applicable voluntary standards
 - have third party certification from an accredited laboratory
 - be built consistently and with proper quality and safety
 - have product safety standards that are continuously updated to address hazards identified by incident data



Outline

Part 1: Data

- Basics on CPSC's Databases
- **Battery Incident Data**
- Recalls

Part 2: Lithium-Ion Battery-Powered Product Case Studies

- No Product Standard (Before UL 2272) – Electric Scooters/Hoverboards
- Well-Developed Standards – Cell Phones and Laptops
- Lessons Learned – System Safety



CPSC Battery Project Scope

- Commission directed CPSC staff to:
 - Address hazards associated with high energy density batteries in consumer products (Lithium-ion batteries)
 - Efforts to include enforcement, voluntary and mandatory standards work, import surveillance and compliance, and industry, interagency, and intergovernmental cooperation
 - Project effort intended to address battery hazards by assessing manufacturing technologies, safety features/circuits, packaging, charging features and end-product system integration issues
- 2017 assessment will direct future projects/activities



Relevant Voluntary Standards Activity

- Hoverboards/Electric Scooters - New Outline of Investigation (1/16), ANSI/CAN/UL 2272-16 *Electrical Systems for Personal E-Mobility Devices* (11/16)
- ASTM F963-16 Toy Safety (11/16) - CPSC Toy Regulation 4/30/17
- IEEE 1725-2011 Cellular Telephones - Certification and standard updates
- IEEE 1625-2008 Mobile Computing - Certification and standard updates
- Baby Monitors ASTM F2951-13 – Add battery requirements from ASTM F963 or UL 62368-1 requirements
- E-Cigarettes (FDA) – UL 8139 (3/17) *Outline of Investigation for Electrical Systems of Electronic Cigarettes*



CPSRMS Summary (Top 30 Product Codes)

PROD	Hits	Product Description
884	10031	BATTERIES
557	3399	COMPUTERS (EQUIPMENT AND ELECTRONIC GAMES)
4062	2906	ELECTRIC WIRE OR WIRING SYSTEMS (EXCL PANELBOARDS RECEPT
550	2594	TELEPHONES OR TELEPHONE ACCESSORIES
883	1813	BATTERY CHARGERS
1394	1190	DOLLS, PLUSH TOYS, AND ACTION FIGURES
(blank)	1073	#N/A
5021	739	TOY VEHICLES (EXCLUDING RIDING TOYS)
821	548	AUTOMOTIVE TOOLS OR ACCESSORIES
4061	487	ELECTRIC OUTLETS OR RECEPTACLES
639	448	FLASHLIGHTS OR BATTERY-POWERED LANTERNS
1330	413	POWERED RIDING TOYS
5042	366	SCOOTERS / SKATEBOARDS, POWERED
1553	322	PORTABLE BABY SWINGS (FOR HOME USE)
546	315	STEREO OR HI-FI COMPONENTS OR ACCESSORIES
1550	315	INFANT & TODDLER PLAY CTRS, EXCL JUMPERS,BOUNCERS&EXERCISERS
1526	280	CRIB MOBILES OR CRIB GYMS
1807	278	FLOORS OR FLOORING MATERIALS
536	276	PHOTOGRAPHIC EQUIPMENT
1365	249	WATER TOYS
702	234	FIRE OR SMOKE ALARMS
676	163	RUGS OR CARPETS, NOT SPECIFIED
855	135	PORTABLE POWER DRILLS AND ACCESSORIES
4083	134	SURGE SUPPRESSORS OR POWER STRIPS
4039	124	OTHER ELECTRIC LIGHTING EQUIPMENT
573	118	OTHER SOUND RECORDING, REPRODUCING OR RECEIVING EQUIP.
278	108	ELECTRIC RANGES OR OVENS (EXCL COUNTER-TOP OVENS)
679	104	SOFAS, COUCHES, DAVENPORTS, DIVANS OR STUDIO COUCHES
1558	99	BABY BOUNCER SEATS (EXCL. JUMPERS)
5040	89	BICYCLES AND ACCESSORIES, (EXCL.MOUNTAIN OR ALL-TERRAIN)



CPSRMS Data

- Manually filter incidents categorizing
 - like products
 - battery capacity/size (if available)
- Risk: Fires, explosions, and overheating vs. smoke and melting
- Exclude:
 - Non-lithium-ion batteries
 - Charger (isolated from battery issue)
 - Cords (isolated from battery issue)
- Data are raw
 - Not for statistical analysis
 - Anecdotal
 - Duplicates



Laptop CPSRMS Incident Data

(2012-2017)

- Over 3000 incidents involving computer battery or charger or both
 - Fire, overheating, melting, smoking, or explosion
 - 30% mentioned battery
 - 75% mentioned charger or charging
 - Reviewing IDIs to determine cause of incidents



Cell Phone CPSRMS Incident Data

(2012-2017)

- Over 2000 incidents involving cell phone battery or charger or both
 - Fire, overheating, melting, smoking, or explosion
 - 30% mentioned battery
 - 80% mentioned charger or charging
 - Reviewing IDIs to determine cause of incidents



Power Bank CPSRMS Data

(2012-2017)

- Power Bank – Portable USB charger or back-up battery power
- Over 400 incidents involving power bank charging
 - Fire, overheating, melting, smoking, or explosion
 - Charging or charging another product
 - Reviewing IDIs to determine cause of incidents



CPSRMS Drone Data

(2012-2017)

- Over 200 incidents involving drones
 - Fire, overheating, melting, smoking, or explosion
 - Over 50% while charging
 - Over 100 injuries related to lacerations or contusions (NEISS Data)
 - Reviewing IDIs to determine cause of incidents
 - Although incidents are reported on CPSRMS, drones are not within CPSC jurisdiction



CPSC E-Cigarette Fire and Explosion Data (Food and Drug Administration Jurisdiction)

- Through 2016 – 34 Emergency room visits (NEISS*)
 - 29 Explosions, 5 Fires
- Location of Battery or E-Cigarette Device
 - 23 In pocket (19 Batteries), 4 In hand, 3 Near thigh, 2 In Face, 1 Near eye, 1 In car charger
- Injuries
 - 32 burns – 1 electrical, 4 chemical, and 27 thermal; 2 Lacerations
- Ages (16 to 57)
 - 11 Ages (16 to 24)
 - 12 Ages (25 to 34)
 - 8 Ages (35 to 44)
 - 3 Age 45 or older

*Data insufficient to generate national estimate



Outline

Part 1: Data

- Basics on CPSC's Databases
- Battery Incident Data
- **Recalls**

Part 2: Lithium-Ion Battery-Powered Product Case Studies

- No Product Standard (Before UL 2272) – Electric Scooters/Hoverboards
- Well-Developed Standards – Cell Phones and Laptops
- Lessons Learned – System Safety



Recalls of Lithium-ion Battery Products (2012-2017)

- 49 Recalls of Lithium-ion Battery-Powered Products

Product	# of Recalls	# Recalled
Hoverboard	11	502,200
Laptop	11	498,162
Flashlight/Lantern	3	18,305
Tablet	2	83000
Power Bank	4	211325
Charger	3	684007
Battery Backup	1	2500
Jumpstarter	2	14814
E-Bike	1	5000
UPS	1	2876
Cell Phone	1	1920927
Other*	9	289692
	Total	4,232,808

*Other products include baby monitor, gloves, hand warmers, RC car battery pack and wireless speakers



Recalls of Lithium-ion Battery Products (2012-2017)

- Recalls – 49
 - Products Involved – 4,232,808
 - Samsung Note 7s – 1,920,927
 - Electric Scooters – 500,000+
 - Ryobi Charger and Battery – 637,707
 - Laptop Computers – 368,299



Recalls of Lithium-ion Battery Products

- Root Causes
 - Battery Management System (BMS)
 - Cell Manufacturing quality control (QC)
 - Lack of system integration (Charger-BMS-Cells)
 - Non-Listed cells/systems
- Standards (voluntary or mandatory)
 - Addressable
 - Non-addressable



Reasons for Previous Recalls

- Battery Pack Design Problems
 - Lacks safety circuits
 - Lacks adequate (or any) overcharge/over-discharge protection
 - Lacks adequate physical protection
- Quality Control Problems in Cell Manufacturing
 - Improper placement of leads
 - Contaminants in cell
 - Uneven forming of cell
 - Welding sharp edges on tab (new)
 - Missing insulating tape on tab (new)



Cylindrical Cell Contaminant

- Iron (Fe) particle adhered to electrode
- Particle from moving chuck
- Chuck is used to position electrode for cutting
- Metallic particles can perforate separator and short electrodes in certain areas

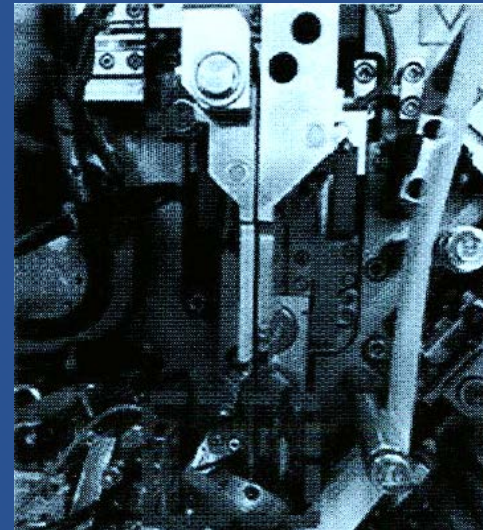
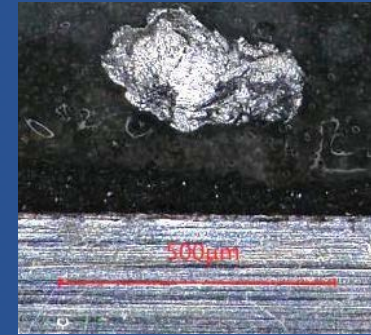

Cylindrical Cell Contaminant Mitigation

- Root Cause: Chuck was repositioned improperly when interference occurred
- Correct alignment of chuck
- Track assembly line production from affected dates
- Limit scope of recalled products
- Implement process to control further issues with chuck alignment
- Reduce other metal-to-metal processes in cell manufacturing



Contamination Mitigation

- Processes used to mitigate cell contamination
 - Magnets used to capture ferrous particles
 - Suction used to capture other particles
 - Air ventilation and filtration systems in production areas to minimize contaminants
 - Cell dissection to look for foreign particles
 - X-rays – non-destructive inspection for foreign particles and assembly anomalies
 - CT Scanner – more detailed non-destructive inspection



Physical Damage

- Damaged outer foil in polymer cell
- Causing internal soft short
- Visual inspections are needed to identify problems and initiate corrective actions before cells leave factory

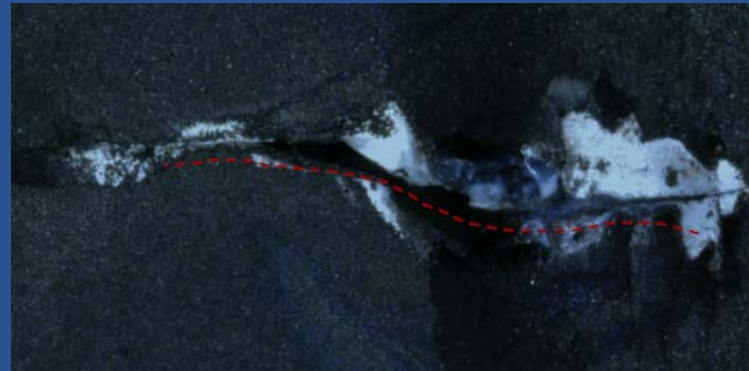

Electrode Alignment

- Sufficient electrode overlap
- Mitigates risks of short circuit from lithium plating on edge
- Negative overlap $> 100 \mu\text{m}^*$

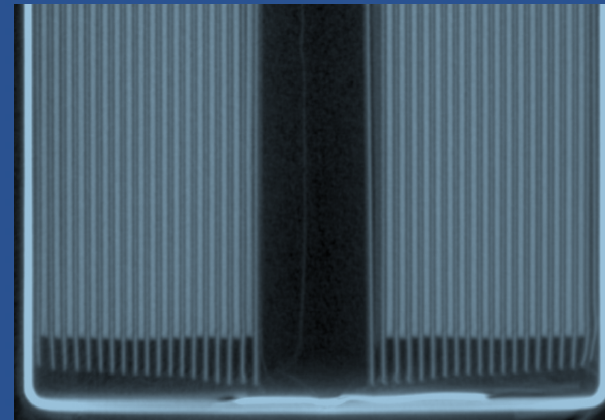
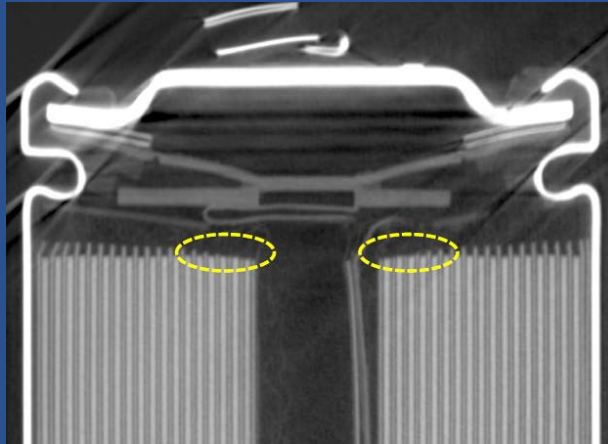

* IEEE 1625 (Laptops) and IEEE 1725 (Cell phones) standards



Internal Cell Faults



U.S. Consumer Product Safety Commission
National Product Testing and Evaluation Center
Rockville, Maryland

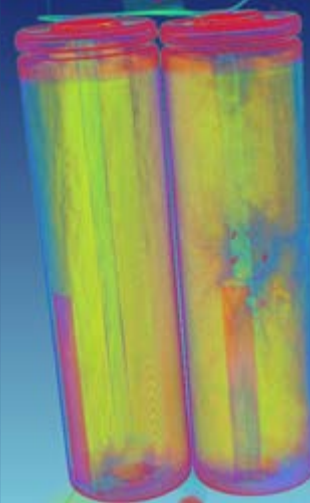
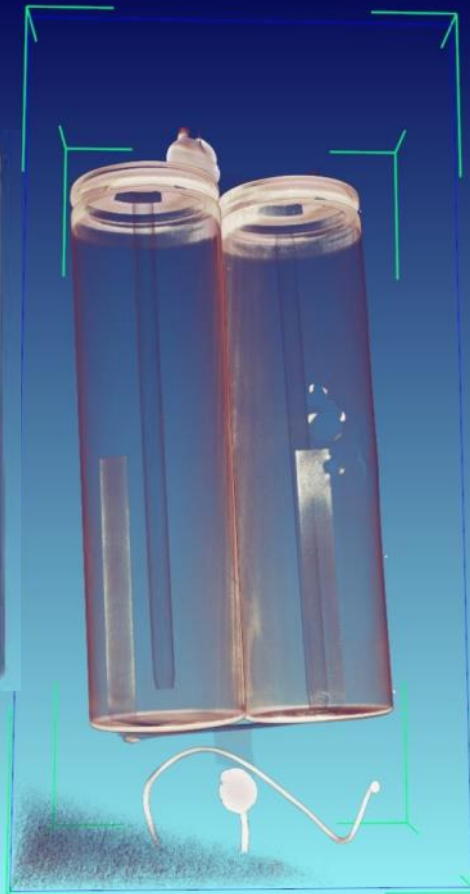

- CT Scans and X-rays used to evaluate internal cell faults



CPSC Staff Ultrasonic Welding Evaluation – Tabs

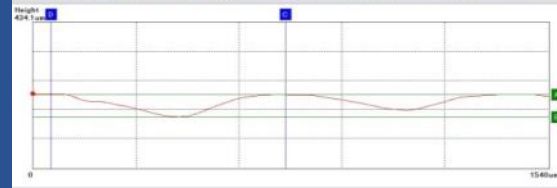
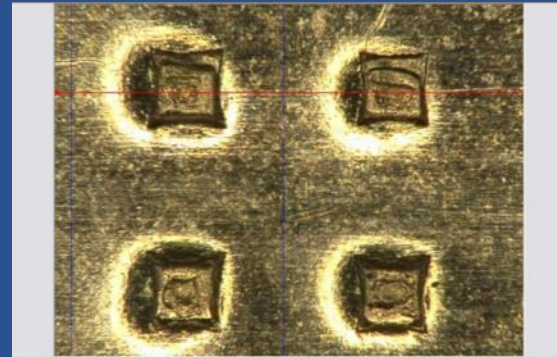
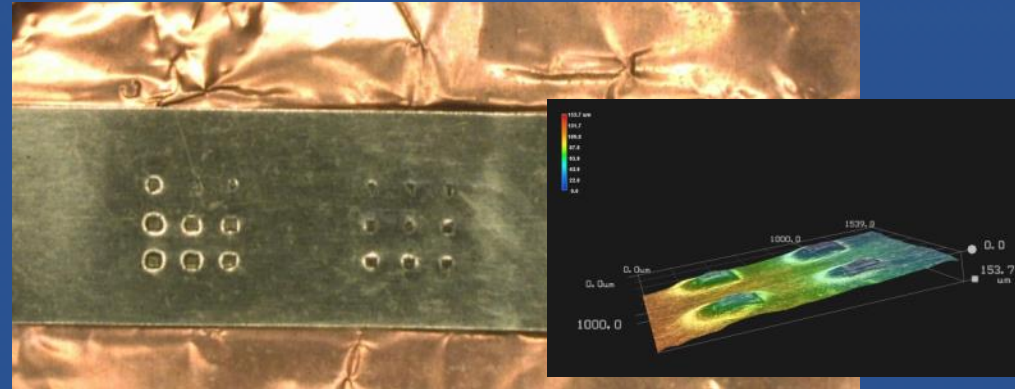

Each Layer thickness

- Separator = 10 ~ 20 μm
- Tabs = 20 ~ 80 μm
- Cu and Al foil = 10 ~ 20 μm
- Coatings = 40 ~ 60 μm



CPSC Staff Thermal Runaway Sample Evaluation

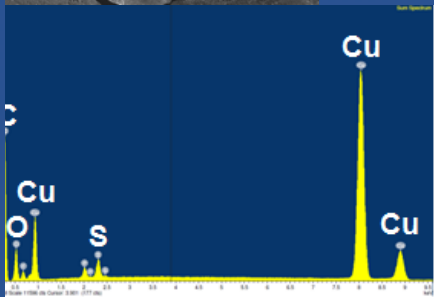
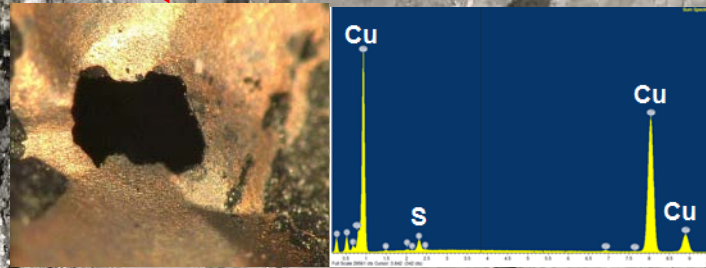
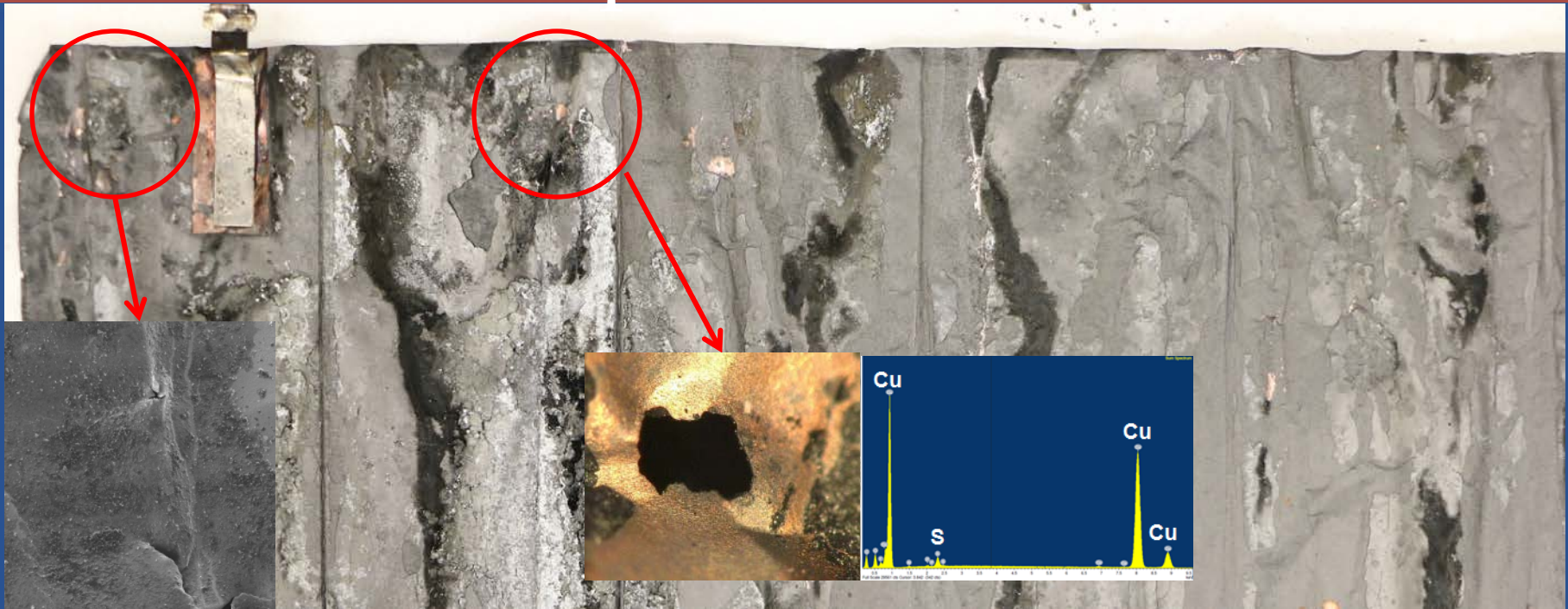

- Evaluation of potential internal shorts via high-powered optical microscope and SEM/EDS
- Any hole or anomalies are evaluated.
- A part of copper foil can be consumed during thermal runaway or initial internal shoring.



Outline

Part 1: Data

- Basics on CPSC's Databases
- Battery Incident Data
- Recalls

Part 2: Lithium-Ion Battery-Powered Product Case Studies

- **No Product Standard (Before UL 2272) – Electric Scooters/Hoverboards**
- Well-Developed Standards – Cell Phones and Laptops
- Lessons Learned – System Safety



Self-Balancing Electric Scooters or Hoverboards

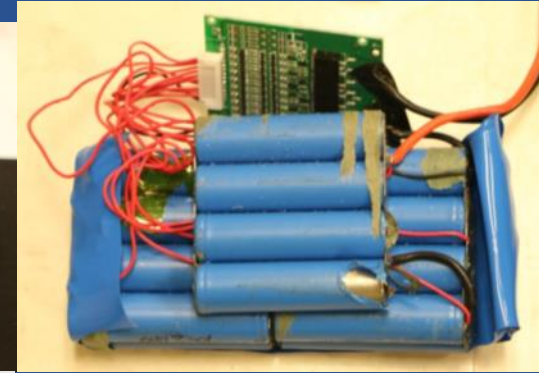

Incidents from Self-Balancing Electric Scooters or Hoverboards



Incidents from Self-Balancing Electric Scooters or Hoverboards

- Over 165 fire incidents, causing over \$3M in property damages
 - Incidents occurred in 38 states
 - During and after charging
 - During and after riding
- 3 Deaths – 1 fire (2 victims, young girls), 1 fall (MVA death excluded)
- Estimated over 10,000 Emergency Room Visits
 - ~90% from falls, e.g. sudden stops and starts
 - ~15% head injuries
 - ~50% arm injuries
 - ~40% fractures
 - ~30% sprain/abrasions



Temperature Management Sensor Not Used

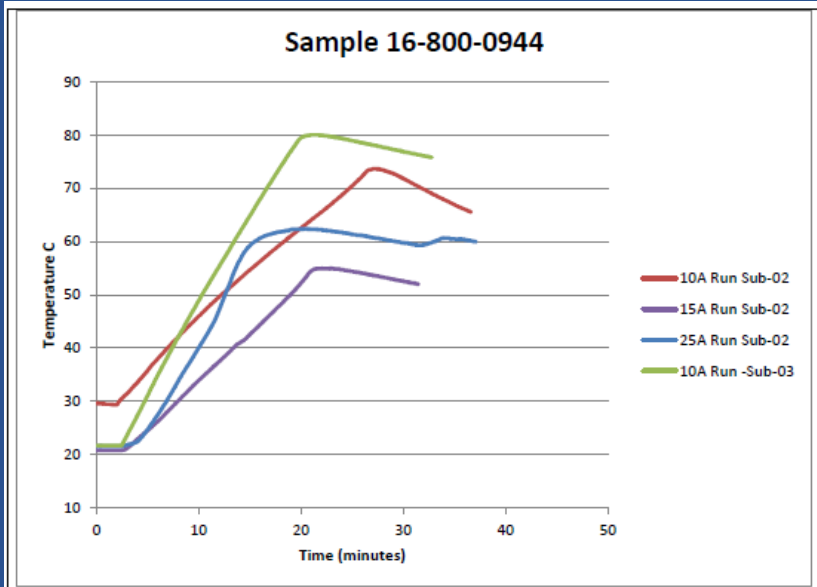

8	Temperature	Operating Temperature Range	-40 ~ +85°C
		Storage Temperature Range	-40 ~ +125°C
		Discharging Temperature protection	65±5°C

Size: L63*W55*T7mm

B + / P + = Charge + / Discharge +
C - = Charge - / Discharge -
P - = NC

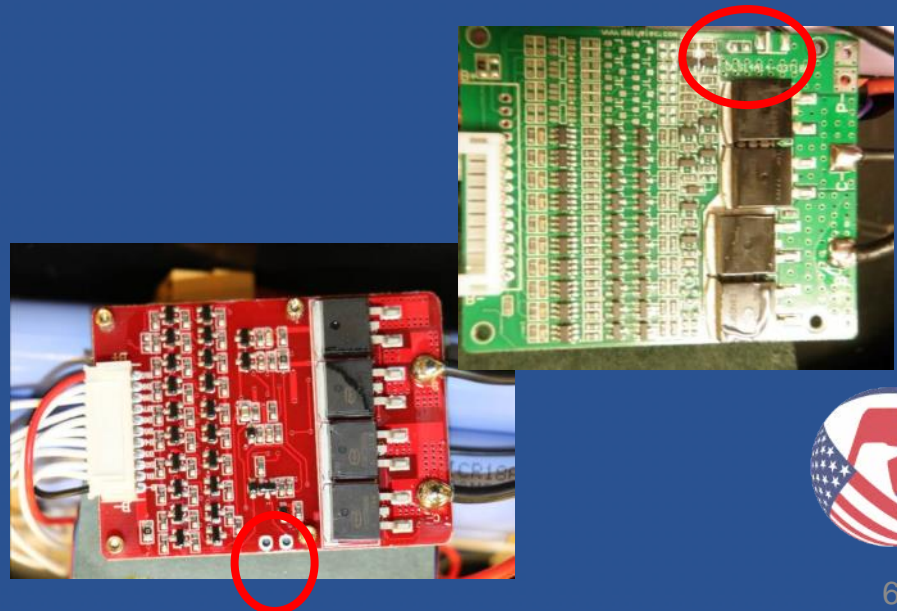
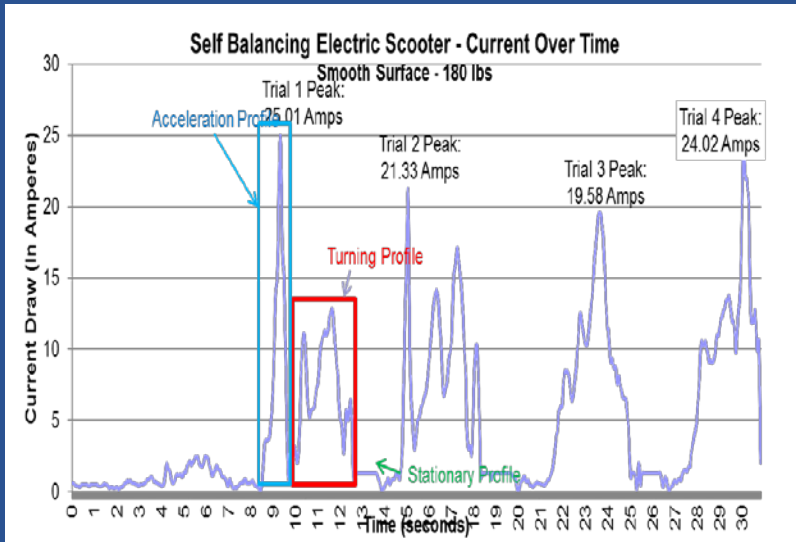

Staff Hoverboard Assessment

- Staff thoroughly tested and analyzed units on market, found that many used uncertified lithium-ion cells/chargers and did not follow typical safe cell operating practices to protect against operation at excessive temperatures, overcharging or over-discharging.
- Units posed fire hazard.
- Fire incident units exhibited signs of thermal runaway leading to catastrophic failure of the entire battery pack



Hoverboard Evaluation Results

- Inadequate Battery Management System – Failed protective circuit safety analysis
- Inadequate cells (pack) for system loading
- Cells not certified to standards to ensure cells are manufactured to best practices
- Battery chargers not certified to appropriate standard, UL 1310, UL 1012, UL 60950-1
- Wiring improperly secured and protected in the pivot base, exposed connections
- > 500,000 units recalled



Internal Wiring

- Wiring throughout hoverboard should be using best practices
 - Securing loose wires
 - Routing wires to prevent stress and cold flow

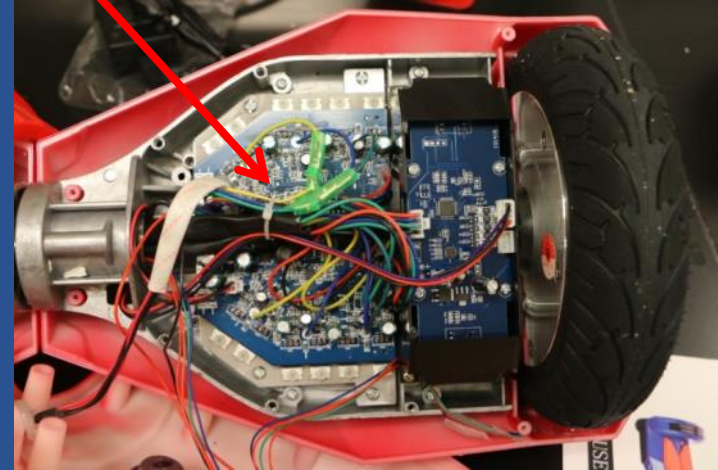
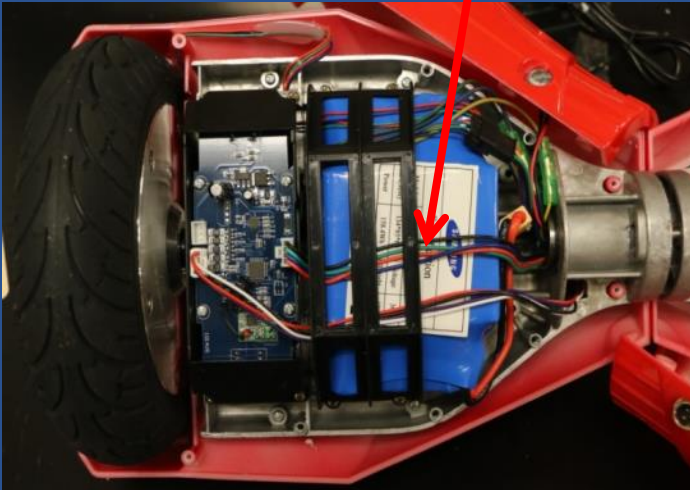

Internal Wiring

- Wiring throughout hoverboard should be using best practices
 - Protective wire sheathing throughout pivot
 - Casting deburred to prevent short circuits

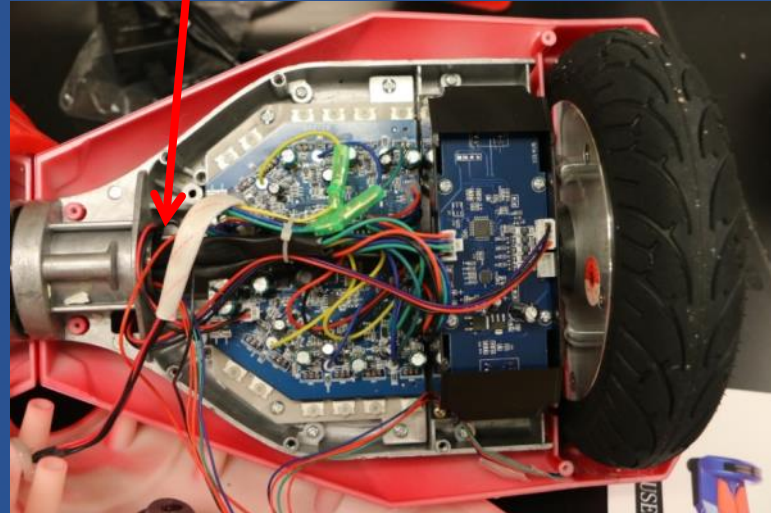
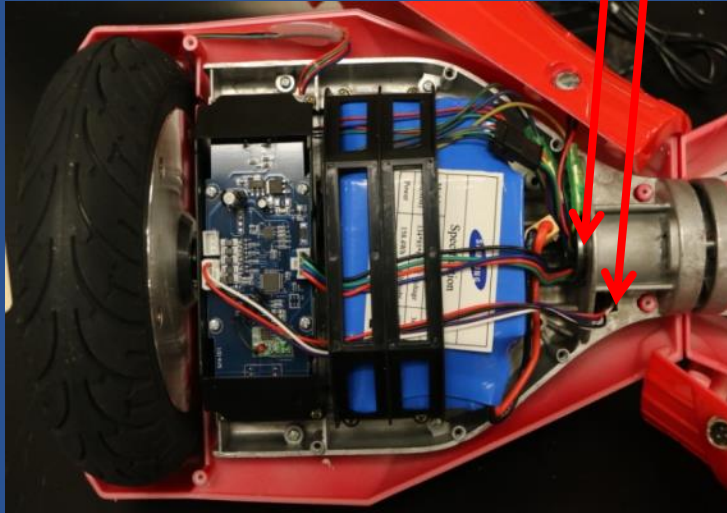
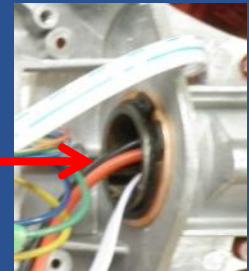

Hover Board Voluntary Standards – Staff Participation

- UL 2272 - Outline of Investigation for Electrical Systems for Self-Balancing Scooters (January 2016)
- UL 2272 - Electrical Systems for E-Mobility Devices (November 2016)
 - Covers the electrical system –cells, pack, charger, and the entire product as a system
- ASTM International working on requirements for mechanical safety



Outline

Part 1: Data

- Basics on CPSC's Databases
- Battery Incident Data
- Recalls

Part 2: Lithium-Ion Battery-Powered Product Case Studies

- No Product Standard (Before UL 2272) – Electric Scooters/Hoverboards
- **Well-Developed Standards – Cell Phones and Laptops**
- Lessons Learned – System Safety



Well-Developed Standards

- Cell phones (IEEE 1725) and Laptops (IEEE 1625) are not immune to incidents



Source: Google images



Manufacturing Design Issue A*

Root Cause: Manufacturer A

- Based on the results of analysis and testing, the most likely root cause for the thermal failure of certain Manufacturer A cells was determined to be unintended damage to the negative electrode windings consistently in the corner of the cell closest to the negative tab
 - The unintended damage was present in all of the cells examined by Samsung and Exponent
 - The damage was caused by a cell pouch design that provided inadequate volume to accommodate the electrode assembly
 - The observed damage provides multiple potential routes to internal cell faulting and thermal failure with normal cycling, including compromise of the separator and lithium plating
- Exponent's initial analysis of cells from Manufacturer B showed no deficiencies in the pouch, design or manufacturing
 - Manufacturer B cells manufactured after our initial investigation was complete were shown to contain a distinctly different defect that was not present in the initial cells we investigated

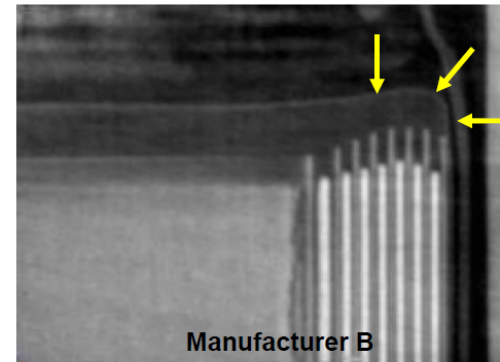
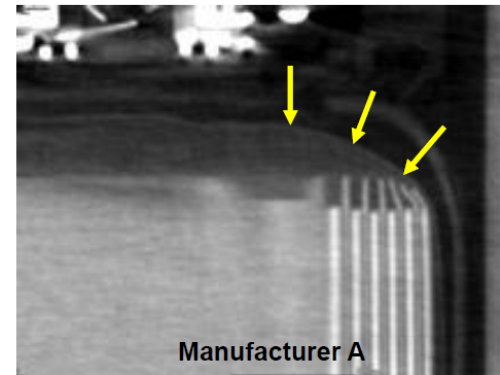

Manufacturing QC Issue B*

Root Cause: Manufacturer B

- Based on the results of analysis and testing, the most likely root cause for the thermal failure of Manufacturer B cells was determined to be internal cell faulting between positive electrode tab welding defects and the copper foil of the negative electrode directly opposite the defective welds
 - Welding defects in some incident cells were found to be tall enough to bridge the distance to the negative electrode foil
 - Some cells examined were assembled without protective tape over the positive electrode tab, increasing the likelihood of an internal cell fault

Positive Tab



Negative Electrode
Opposite Positive Tab



IEEE 1725 Requirements Review and Staff Recommendations

- Cell core assembly
 - Corner clearance validation process
- Detection of damaged cores
- Cell Aging
- Testing procedures
- Dissection of cycled cells
 - verify 4 corners - radius (prismatic/polymer)
 - verify top and bottom of core (cylindrical)



IEEE 1725 Requirements Review and Staff Recommendations

- Cell Aging
- Dissection of cycled cells
 - (proposed) verify electrode tab welds
 - (proposed) verify insulation tape at tabs in key areas such as the electrode ends and radius of
 - (proposed) verify insulation tape at electrode ends
 - (proposed) verify insulation tape at radius



IEEE 1725 Requirements Review and Staff Recommendations

- User Interactions and Responsibilities (information to user)
 - (proposed) Remove from pants pocket when sitting
 - (proposed) Cases are recommended to protect the phone from physical damage
- (proposed) External forces requirement: drop, impact, and flexing test requirements
 - Dissection of tested units
- Global review to update referenced standards and technology changes



IEEE 1625 Requirements Review and Staff Recommendations

- Review IEEE 1625 changes to incorporate IEEE 1725 changes as applicable
- Global review to update referenced standards and technology changes



Outline

Part 1: Data

- Basics on CPSC's Databases
- Battery Incident Data
- Recalls

Part 2: Lithium-Ion Battery-Powered Product Case Studies

- No Product Standard (Before UL 2272) – Electric Scooters/Hoverboards
- Well-Developed Standards – Cell Phones and Laptops
- **Lessons Learned – System Safety**



Lithium-Ion Battery Safety

- High energy density – driven by consumer demand
- Electrode chemistries – LCO, LMO, NMC, and LFP
- Flammable electrolytes
- Requires critical safety circuits* to control voltage, current and temperature during charge and discharge

*Safety circuits do not address internal cell shorts

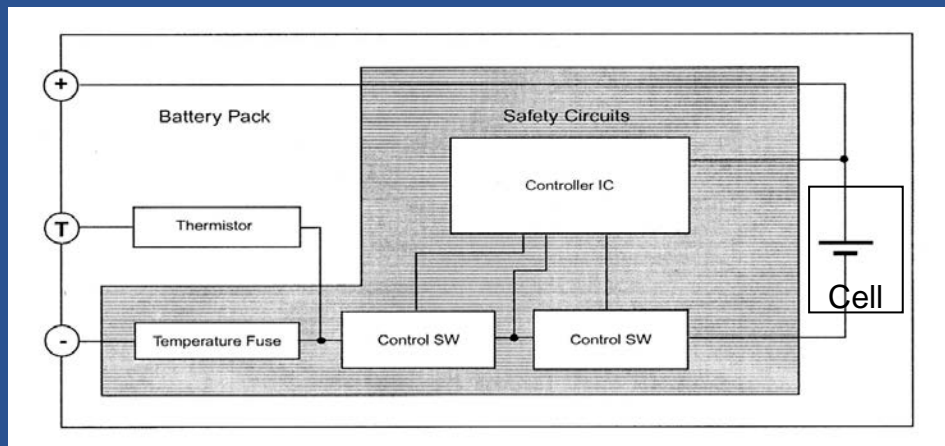

Single-cell
battery pack
with safety
circuits



Guide to Safe Battery Use*

The view of a safety region (charge)

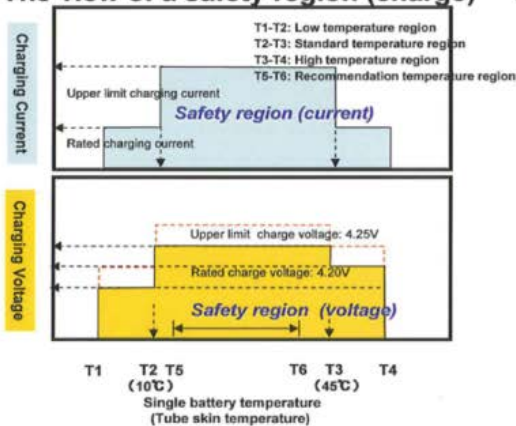

The view of a safety region (discharge)

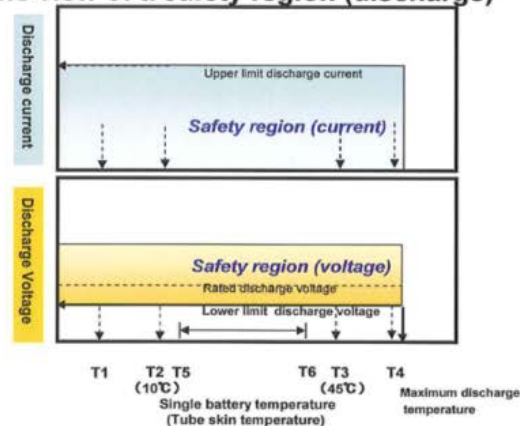

Temperature domain	- T1	T1-T2	T2-T5	T5-T6	T6-T3	T3-T4	T4-
Capacity	Small	Design center value			Almost similar		
Characteristic	×	△	○	◎	○	△	×
Safety	×	○	○	○	○	○	×

- 14 -

*Japan Electronics and Information Technology Industries Association and Battery Association of Japan Source: http://home.jeita.or.jp/page_file/20110517171451_cub9MvYFEh.pdf



Manage Voltage, Current and Temperature*

- Max charge voltage - 4.2V
- Min discharge voltage ~2.75V
- Max charge current C – capacity in A
- Max discharge current 2C or specified rate
 - 8.8A (2C) vs. 20A (5C - high discharge)
- Charge temperature - 0 to 45 °C
- Use temperature - 0 to 60 °C

*Values dependent on cell and chemistry



Manage Additional Charging Parameters

- Maintain balanced cells in multi-cell packs
- Disable charging if cell surface temperatures are $> 45\text{ }^{\circ}\text{C}$
- Disable charging or initiate pre-charge charging rate if cell is below 3 V
- Disable charging when charge current drops to .05C (no trickle charging)

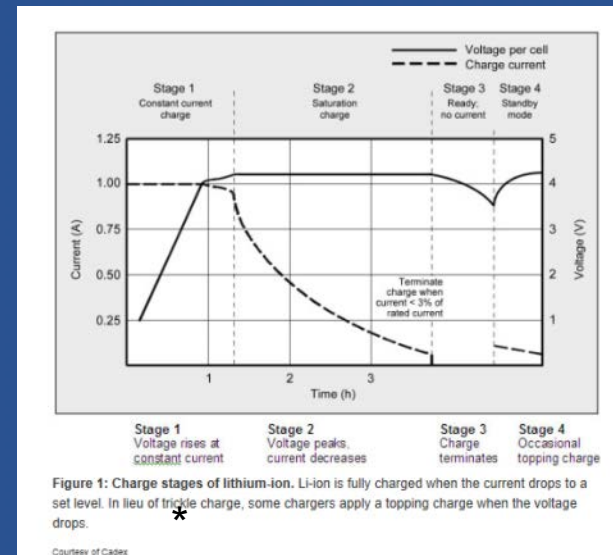

*Source:

http://batteryuniversity.com/learn/article/charging_lithium_ion_batteries



Thermal Management

- Thermal sensors
- Thermal insulators

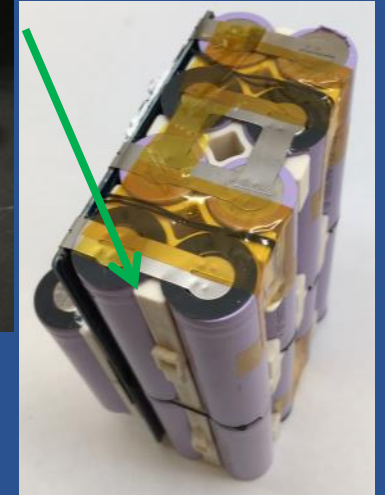
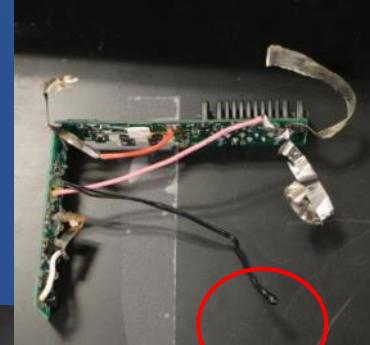
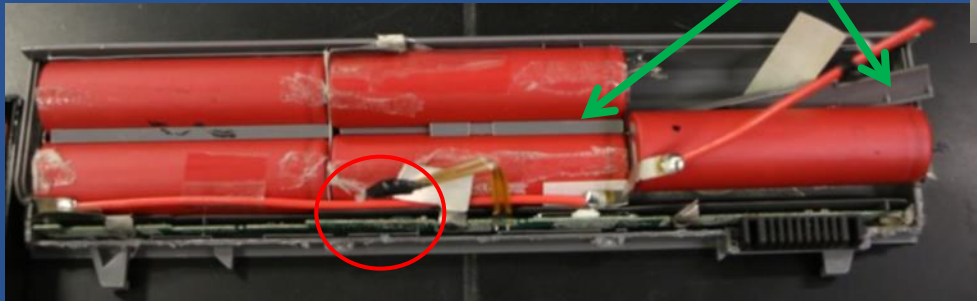

18650 Internal Cell Safety Features

- CID – Charge Interrupting Device
- Resettable PTC – Positive Temperature Coefficient
 - Do not protect against thermal runaway due to internal faults
 - May not be applicable for high-drain applications

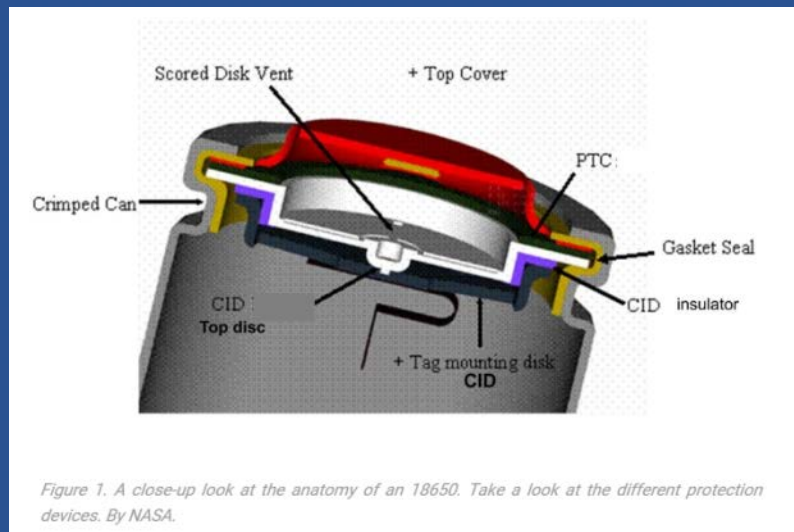

Source: <https://batterybro.com/blogs/18650-wholesale-battery-reviews/18306003-battery-safety-101-anatomy-ptc-vs-pcb-vs-cid>



Battery Management System (BMS) Required

- User replaceable cells need integral BMS
 - Over-charge protection
 - Charge protection
 - Over-discharge protection
 - External short-circuit protection

This board has the following features:

1. Over-charge protection
2. Charge protection
3. Over-discharge protection
4. Over-current protection
5. Short protection

This is what an 18650 battery looks like when it is connected to a PCB:



Figure 5. The anatomy of a protected 18650 battery by Lygte Info

Source: <https://batterybro.com/blogs/18650-wholesale-battery-reviews/18306003-battery-safety-101-anatomy-ptc-vs-pcb-vs-cid>



Follow Best Practices – Avoid Unsafe Products

Case Study: Remote control toy helicopters provided with rechargeable lithium-ion batteries without charge/discharge control circuitry or thermal protection, allowing batteries to be overcharged or over-discharged, overheat and ignite. Posed fire hazard.

Units recalled.

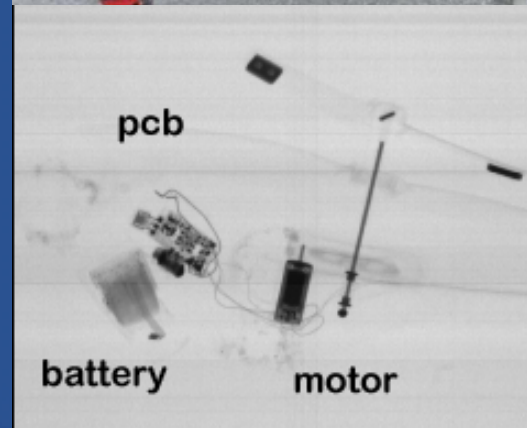
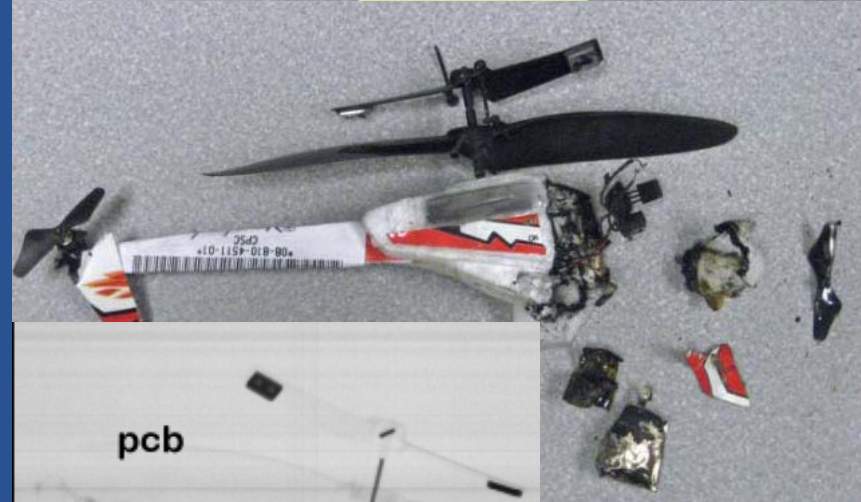

CPSC Staff Recommendations for Safe Lithium-ion Battery Products

- Components and End Products should be certified to the applicable industry voluntary standard including:
 - Cells
 - Battery Pack with BMS safety circuits
 - Charger
 - End Product System
- Standards need continuous updating to ensure they address new technology and safety issues



Summary

Lithium-ion battery safety requires diligence from producer to user.

- Lithium-ion battery products should:
 - be designed and built using high quality cells
 - in accordance with applicable voluntary standards
 - suitable for the application and intended loads
 - in collaboration with cell and battery pack manufacturers
 - manufactured to best manufacturing quality control processes
 - recommended to be certified cells
 - built consistently and with proper quality and safety
 - have quality and configuration control maintained
 - have impact assessment of material or component substitutions
 - have proper warning labels to inform/educate users of the potential hazards and to closely follow manufacturer's instructions for proper use
 - have third-party certification from an accredited laboratory
 - have product safety standards that are continuously updated to address hazards identified by incident data



Questions?

