

SOLICITATION/CONTRACT/ORDER FOR COMMERCIAL ITEM
OFFEROR TO COMPLETE BLOCKS 12, 17, 23, 24, & 30

1. REQUISITION NUMBER: REQ-8100-11-0017
PAGE OF: 1 28

2. CONTRACT NO: CPSC-S-11-0053
3. AWARD/EFFECTIVE DATE: 05/23/2011
4. ORDER NUMBER:
5. SOLICITATION NUMBER: CPSC-Q-11-0026
6. SOLICITATION ISSUE DATE: 02/17/2011

7. FOR SOLICITATION INFORMATION CALL: Germaine Myles
8. TELEPHONE NUMBER (No collect calls): (301) 504-7669
9. OFFER DUE DATE/LOCAL TIME: ET

9. ISSUED BY: CONSUMER PRODUCT SAFETY COMMISSION
DIV OF PROCUREMENT SERVICES
4330 EAST WEST HWY
ROOM 517
BETHESDA MD 20814
CODE: FMPS
10. THIS ACQUISITION IS:
 UNRESTRICTED OR
 SET ASIDE:
% FOR:
 SMALL BUSINESS
 EMERGING SMALL BUSINESS
NAICS:
 HUBZONE SMALL BUSINESS
 SOLE SOURCE
SIZE STANDARD:
 SERVICE-DISABLED VETERAN-OWNED SMALL BUSINESS
 (A)

11. DELIVERY FOR FOB DESTINATION UNLESS BLOCK IS MARKED
 SEE SCHEDULE
12. DISCOUNT TERMS: Net 30
13a. THIS CONTRACT IS A RATED ORDER UNDER DPAS (15 CFR 700)

13b. RATING:
14. METHOD OF SOLICITATION:
 RFQ
 IFB
 RFP

15. DELIVER TO: CONSUMER PRODUCT SAFETY COMMISSION
FIELD INVESTIGATIONS BRANCH (EAST)
4330 EAST WEST HIGHWAY
BETHESDA MD 20814
CODE: CFIE
16. ADMINISTERED BY: CONSUMER PRODUCT SAFETY COMMISSION
DIV OF PROCUREMENT SERVICES
4330 EAST WEST HWY
ROOM 517
BETHESDA MD 20814
CODE: FMPS

17a. CONTRACTOR/OFFEROR: HAMILTON COUNTY OF
250 WILLIAM HOWARD TAFT RD
2ND FLOOR
CINCINNATI OH 45219-2630
CODE:
FACILITY CODE:
18a. PAYMENT WILL BE MADE BY: CPSC Accounts Payable Branch
AMZ 160
P. O. Box 25710
Oklahoma City OK 73125
CODE: FMFS

17b. CHECK IF REMITTANCE IS DIFFERENT AND PUT SUCH ADDRESS IN OFFER
18b. SUBMIT INVOICES TO ADDRESS SHOWN IN BLOCK 18a UNLESS BLOCK BELOW IS CHECKED
 SEE ADDENDUM

19. ITEM NO.	20. SCHEDULE OF SUPPLIES/SERVICES	21. QUANTITY	22. UNIT	23. UNIT PRICE	24. AMOUNT
	DUNS Number: [REDACTED] Project Officer: Beverly Kohen bkohen@cpsc.gov (516) 938-5215 The contractor shall provide the following service in accordance with the attached Statement of Work (SOW) and terms and conditions to perform Pool Inspections in the state of Ohio in accordance with the Virginia Graeme Baker Pool (Use Reverse and/or Attach Additional Sheets as Necessary)				

25. ACCOUNTING AND APPROPRIATION DATA: 0100A11DPS-2011-3222300000-EXFM003000-252A0
26. TOTAL AWARD AMOUNT (For Govt. Use Only): \$21,000.00

27a. SOLICITATION INCORPORATES BY REFERENCE FAR 52.212-1, 52.212-4, FAR 52.212-3 AND 52.212-6 ARE ATTACHED. ADDENDA ARE ARE NOT ATTACHED.
27b. CONTRACT/PURCHASE ORDER INCORPORATES BY REFERENCE FAR 52.212-4, FAR 52.212-5 IS ATTACHED. ADDENDA ARE ARE NOT ATTACHED.

28. CONTRACTOR IS REQUIRED TO SIGN THIS DOCUMENT AND RETURN COPIES TO ISSUING OFFICE. CONTRACTOR AGREES TO FURNISH AND DELIVER ALL ITEMS SET FORTH OR OTHERWISE IDENTIFIED ABOVE AND ON ANY ADDITIONAL SHEETS SUBJECT TO THE TERMS AND CONDITIONS SPECIFIED HEREIN.
29. AWARD OF CONTRACT REF. OFFER DATED: YOUR OFFER ON SOLICITATION (BLOCK 5), INCLUDING ANY ADDITIONS OR CHANGES WHICH ARE SET FORTH HEREIN, IS ACCEPTED AS TO ITEMS:

30a. SIGNATURE OF OFFEROR/CONTRACTOR: [Signature]
30b. NAME AND TITLE OF SIGNER (Type or print): Health Commission
30c. DATE SIGNED: 5-24-11
31a. UNITED STATES OF AMERICA (SIGNATURE OF CONTRACTING OFFICER): [Signature]
31b. NAME OF CONTRACTING OFFICER (Type or print): Rudi M. Johnson
31c. DATE SIGNED: 5/26/2011

19. ITEM NO.	20. SCHEDULE OF SUPPLIES/SERVICES	21. QUANTITY	22. UNIT	23. UNIT PRICE	24. AMOUNT
	and Spa Safety Act Public Law No. 110-140. The performance of work shall begin five (5) days after meeting or conference call with CPSC Project Officer and shall not extend beyond one hundred and twenty (120) days. Base Year Period: May 25, 2011 through April 15, 2012.				
0001	Pool Inspections - Two hundred ten (210) sites. First Option Year Period: April 16, 2012 through October 15, 2012.	210	EA	100.00	21,000.00
0002	Pool Inspections - Two hundred thirty six (236) sites. Amount: \$23,600.00 (Option Line Item) The total amount of award: \$44,600.00. The obligation for this award is shown in box 26.	236	EA	100.00	0.00

32a. QUANTITY IN COLUMN 21 HAS BEEN RECEIVED INSPECTED NOTED: _____ ACCEPTED, AND CONFORMS TO THE CONTRACT, EXCEPT AS

32b. SIGNATURE OF AUTHORIZED GOVERNMENT REPRESENTATIVE	32c. DATE	32d. PRINTED NAME AND TITLE OF AUTHORIZED GOVERNMENT REPRESENTATIVE		
32e. MAILING ADDRESS OF AUTHORIZED GOVERNMENT REPRESENTATIVE		32f. TELEPHONE NUMBER OF AUTHORIZED GOVERNMENT REPRESENTATIVE		
		32g. E-MAIL OF AUTHORIZED GOVERNMENT REPRESENTATIVE		
33. SHIP NUMBER <input type="checkbox"/> PARTIAL <input type="checkbox"/> FINAL	34. VOUCHER NUMBER	35. AMOUNT VERIFIED CORRECT FOR	36. PAYMENT <input type="checkbox"/> COMPLETE <input type="checkbox"/> PARTIAL <input type="checkbox"/> FINAL	37. CHECK NUMBER
38. S/R ACCOUNT NUMBER	39. S/R VOUCHER NUMBER	40. PAID BY		
41a. I CERTIFY THIS ACCOUNT IS CORRECT AND PROPER FOR PAYMENT		42a. RECEIVED BY (<i>Print</i>)		
41b. SIGNATURE AND TITLE OF CERTIFYING OFFICER		41c. DATE	42b. RECEIVED AT (<i>Location</i>)	
		42c. DATE REC'D (<i>YY/MM/DD</i>)	42d. TOTAL CONTAINERS	

Statement of Work

Review of Compliance: Virginia Graeme Baker Pool and Spa Safety Act Public Law No. 110-140

I. Background Information

On December 19, 2007, the President signed into law the Virginia Graeme Baker Pool and Spa Safety Act (VGBA or Act), named after the daughter of Nancy Baker and the granddaughter of former Secretary of State James Baker. Graeme Baker died in a tragic incident in June 2002 after the suction from a spa drain entrapped her under water. The legislation that ultimately resulted in this Act was first introduced by Rep. Debbie Wasserman-Schultz (FL) and was supported by the Baker family and Safe Kids Worldwide.

In recent years, there have been an annual average of 283 drowning deaths (2003-2005) and 2,700 emergency room-treated submersion injuries (2005-2007) involving children younger than 5 in pools and spas. In addition, from 1997-2007, there were 74 reported incidents associated with suction entrapment, including 9 deaths and 63 injuries. The new law is aimed at reducing these deaths and injuries by making pools safer, securing the environment around them, and educating consumers and industry on pool safety.

The Act specifies that on or after December 19, 2008, swimming pool and spa drain covers manufactured, distributed, or entered into commerce in the United States must meet specific performance requirements. Additionally, public swimming pools, wading pools, spas and hot tubs must be equipped with drain covers meeting these performance requirements. Drain covers meeting the new requirements are now making their way into the marketplace. Additionally, in certain instances, public pools and spas must have secondary or back-up devices or systems designed to prevent suction entrapment.

II. Authority

Section 29(a) of the Consumer Product Safety Act, 15 U.S.C. 2078(a), requires the Commission to establish a program to promote Federal-State cooperation for the purposes of carrying out this Act.

Section 29(a) (1) provides that the Commission can accept from any State or local authorities engaged in activities relating to health, safety, or consumer protection "assistance in such functions as injury data collection, investigation, and educational programs, as well as other assistance in the administration and enforcement of the Act... and, if so agreed, may pay in advance or otherwise for the reasonable cost of such assistance..."

III. Objective

The objective of this program is to conduct a review of compliance with Section 1404 of the VGBA. In order to review compliance with the new law, State and local officials shall conduct visits to a limited number of pools or spas to determine if the requirements have been met. Documentation and photographs must be provided evidencing compliance or non-compliance with the law. A U.S. Consumer Product Safety Commission (CPSC) Compliance Officer will follow up with the pool owner and/or operators as needed for the appropriate corrective action.

IV. Specifications

Independently, and not as an agent of CPSC, the contractor shall furnish the necessary personnel, materials, services and facilities to perform the work set forth below, except, as specified in Section XVI, Government-Furnished Supplies/Equipment.

V. Work Statement

- A. The contractor shall contact and visit two hundred ten (210) pool sites within the state of Ohio to conduct an onsite inspection to verify compliance of Section 1404 of the VGBA. It shall be noted that each location shall be considered one pool inspection site regardless of the number of pools or spas located at the site. Inspection forms and any necessary training will be provided to the contractor by the CPSC Project Officer. The contractor will provide a proposed list of sites to the Project Officer for approval. The Project Officer will approve or modify the list of inspection sites in writing.
- B. The contractor shall develop two different proposed lists of pool sites (one for the base year and one for the option year with a minimum of fifty pool sites for each) for inspection in the designated jurisdiction and submit the lists with their proposal. Only the base year list and pricing are mandatory. It is NOT mandatory to submit the OPTION YEAR list of sites and pricing. The lists shall also include the population of the area where the pool is located. Approval from CPSC Project Officer to the contractor will be transmitted electronically. **Do not include pools sites for inspection that have been previously inspected under a prior contract with CPSC.**
- C. **Contractor Requirements and Qualifications**

The contractor shall be a State or local government entity with delegated authority and/or jurisdiction for inspecting pools and spas in the State. Personnel performing inspections shall be regular employees of the contractor. Personnel performing inspections shall possess the following minimum qualifications:

 1. The contractor must provide documentation evidencing they are recognized by the State or local government as an inspector with delegated authority and/or jurisdiction for inspecting pools and spas in the State.
 2. Knowledge of swimming pool circulation systems and equipment; and
 3. Knowledge of the VGBA and the minimum requirements that are needed for compliance with the law.
- D. **Limitations on Subcontracting**

Due to the requirement set forth in paragraphs C and E, work cannot be subcontracted to a commercial entity. Should the State or local government entity wish to subcontract to

another State or local government entity to perform a portion of the work, personnel must still meet all of the requirements of these paragraphs and the contractor must obtain prior approval, in writing, from the CPSC Project Officer for any subcontract arrangement. CPSC's contractual relationship will be with the prime contractor only. If any subcontracting occurs, the contractor is responsible for all oversight of, performance requirements of, and payment to, any subcontractor.

E. Commissioning and Credentialing of State and Local Officials

All State and local officials performing inspections of pools and spas pursuant to the Statement of Work shall be Commissioned and issued credentials in accordance with CPSC Directive 0870.2. Commissioning is the legal delegation of authority to State and local officials to accomplish mutually agreed upon tasks to promote consumer product safety. Credentials are a means of official identification and authorize an individual to administer oaths and affirmations and act for the Chairman in the performance of duties provided for in the laws and regulations administered by the Commission. Credentials are issued only to commissioned individuals who require them to perform official duties. Credentials are "For Official Use Only" and shall not be used as a means of personal identification or for personal purposes. After the contract is awarded, the CPSC Project Officer will coordinate with the contractor to facilitate issuance of credentials to delegated State and local officials that will perform inspections under the Statement of Work.

VI. Definitions:

- A. ASME/ANSI** – The term "ASME/ANSI" as applied to a safety standard means such a standard that is accredited by the American National Standards Institute and published by the American Society of Mechanical Engineers.
- B. Barrier.** The term "barrier" includes a natural or constructed topographical feature that prevents unpermitted access by children to a swimming pool, and, with respect to a hot tub, a lockable cover.
- C. Commission.** The term "Commission" means the Consumer Product Safety Commission.
- D. Main drain.** The term means a submerged suction outlet typically located at the bottom of a pool or spa to conduct water to a re-circulating pump.
- E. Safety vacuum release system (SVRS).** The term "safety vacuum release system" means a vacuum release system capable of providing vacuum release at a suction outlet caused by a high vacuum occurrence due to a suction outlet flow blockage.
- F. Swimming Pool; Spa-** The term "swimming pool" or "spa" means any outdoor or indoor structure intended for swimming or recreational bathing, including in-ground and above ground structures, and includes hot tubs, spas, portable spas, and non-portable wading pools.
- G. Unblockable drain.** The term "unblockable drain" means a drain of any size and shape that a human body cannot sufficiently block to create a suction entrapment hazard.

H. State. The term “State” has the meaning given such term in section (a)(10) of the Consumer Product Safety Act, (15 U.S.C. 2052 (10)), and includes the Northern Mariana Islands.

I. Public Pool and Spa Defined.—In this subsection, the term “public pool and spa” means a swimming pool or spa that is—

(A) open to the public generally, whether for a fee or free of charge;

(B) open exclusively to—

(i) members of an organization and their guests;

(ii) residents of a multi-unit apartment building, apartment complex, residential real estate development, or other multi-family residential area (other than a municipality, township, or other local government jurisdiction); or

(iii) patrons of a hotel or other public accommodations facility; or

(C) operated by the Federal Government (or by a concessionaire on behalf of the Federal Government) for the benefit of members of the Armed Forces and their dependents or employees of any department or agency and their dependents.

VII. Inspection

A. Present Notice of Inspection

While conducting the inspection, the contractor shall present the written **Notice of Inspection**, in accordance with CPSC Directive 9010.30, Inspections, to the owner, manager, or person in charge of the establishment to be inspected.

B. Complete Verification of Compliance Form

The contractor shall conduct an on-site inspection of the pool or spa. The contractor shall thoroughly and comprehensively complete this checklist in accordance with checklist parameters. (**See attached Verification of Compliance Form – Attachment - I**). One form must be completed for each pump at the pool inspection site.

All drain covers must be compliant with the ASME/ANSI A112.19.8-2007 standard. If drain covers are field fabricated, then a Registered Design Professional or a licensed professional engineer (PE) or similar professional can specify that the pre-existing grate(s) meets the ASME/ANSI A112.19.8-2007 standard. Secure documentation from the Registered Design Professional or a licensed PE that documents the grate(s) meets the ASME/ANSI A112.19.8-2007 standard.

The manufacturer, contractor, or pool manager may submit written documentation to evidence the size of the sump.

C. Take Photographs

a) The contractor shall photograph the pool area, drain covers, sump and any other suction limiting devices.

- b) These photographs should include close-ups provided the areas are accessible. If they are not accessible, the contractor shall provide a written explanation for not obtaining a photograph in the comments section of the checklist. If the contractor does not have an underwater camera, photographs of the drain covers may be taken from the pool deck.
- c) All photographs must be in color.
- d) Submit digital photographs in electronic format to support documentation.

The Verification of Compliance Form, Notice of Inspection and all supporting documentation including photographs must be submitted as one Adobe Acrobat pdf. or Word document. Label photographs identifying the subject of the photograph (i.e. pool, sump, SVRS, drain, drain covers, etc.) and obtain documentation regarding compliance and any other documents. Specify the site or location of the pool or spa as the name (title) of the document. This will ensure that photographs are matched with the correct pool site. Include dates photographs were taken in the title of the document as well.

If you are unable to convert the documents to an Acrobat Adobe pdf. file, submit all documents in one Microsoft Word document.

D. Obtain Documentation

The contractor shall secure documentation (invoices, bills, etc.) evidencing that the drain covers conform to ASME/ANSI A112.19.8 2007 or successor standard.

VIII. Training

The CPSC Project Officer will provide necessary training to the State or local contractors immediately following the effective date of this contract. The contractor's personnel who will be conducting the inspections must participate in this training. Participation shall be at no cost to the contractor. The Project Officer will coordinate the time and date of training with the contractor.

IX. Deliverables

1. **Participation in meetings:** Within five business days of the award of the contract, the CPSC Project Officer shall meet the contractor at the contractor's facility or via conference call to discuss the services to be provided.
2. **Reports:** The following reports shall be submitted for each site, and shall be submitted electronically to the attention of the Project Officer. Electronic submission is required and will be discussed with the contractor prior to the first assignment to conduct an inspection.
 - a) **Checklist:** The completed "Verification of Compliance Form" shall be submitted electronically. One form must be completed for each pump.
 - b) **Photographs:** All color photographs for a site will be submitted electronically at the same time the checklist is submitted for that site.
 - c) **Final Report:** The contractor shall submit a final report providing a summary list of all contractor's activities during the contract period (list of sites inspected, dates, name of inspectors), including the strengths, weaknesses, and recommendations for improving the overall program.

3. Time of Delivery

- a) Assignments must be completed within 120 days after meeting or conference call in accordance with paragraph IX Deliverables. If there is a delay, the contractor must provide advance written notification to the Project Officer of the reason for the delay in completion.
- b) **Email notification to the Project Officer of non-compliant pools must be submitted within five days of inspection to the Project Officer.** The notification must include the following:
 - I. completed Verification of Compliance Form
 - II. electronic photographs of the Pool or Spa

4. Final Report

A final report must be delivered to the CPSC Project Officer via electronic submission. The final report must provide a summary of all the contractor's activities including but not limited to the following

- a) Pool/Spa inspection completion list including name, address and dates of sites inspected. Include inspector's name that completed each visit.
- b) If available, submit a copy of the State or local pool laws or summary of pending legislation in the jurisdiction where the inspections are conducted.
- c) Summary comments including the strengths, weaknesses, and recommendations for improving the overall program.

X. Period of Performance

Performance of work shall begin immediately after meeting or conference call as described in paragraph IX Deliverables and shall not extend beyond one hundred and twenty (120) days.

XI. LC 5B Project Officer Designation

A. The following individual has been designated as the Government's Project Officer for this contract:

Name: Beverly Kohen

Telephone: 516-938-5215

Email: bkohen@cpsc.gov

Note: Items specified in Section IX. Deliverables shall be sent to the CPSC Project Officer via electronic pdf. or MS Word format.

B. The CPSC Project Officer is responsible for:

- (1) monitoring the contractor's technical progress, including surveillance and assessment of performance, and notifying the contracting officer within one week when deliverables (including reports) are not received on schedule in accordance with the prescribed delivery schedule.
- (2) performing technical evaluation as required, assisting the contractor in the resolution of technical problems encountered during performance; and
- (3) inspection and acceptance of all items required by the contract.

C. The Project Officer is not authorized to and shall not:

- (1) make changes in scope of work, contract schedules, and/or specifications to meet changes and requirements,
- (2) direct or negotiate any change in the terms, conditions, or amounts cited in the contract; and
- (3) take any action that commits the Government or could lead to a claim against the Government.

A clear distinction is made between Government and Contractor personnel. No employer-employee relationship will occur between government employees and contractor employees. Contractor employees must report directly to their company (employer) and shall not report to Government personnel.

XII. LC 3 Acceptance of Deliverables

- a) All materials submitted for approval will be reviewed by the Commission staff within five (5) working days after date of receipt.
- b) Acceptance/rejection will be transmitted to the contractor by the Project Officer, in writing, within five (5) working days after review of products/services.
- c) Acceptance/rejection will be based on conformance with the statement of work and with professional standards.
- d) Upon submission of any contract deliverable, including reports specified in paragraph IX Deliverables number 2, "Reporting Requirements," the contractor shall submit to the Project Officer a copy of the dated cover letter transmitting such deliverable.

XIII. LC 24 Nondisclosure of any Data Developed Under this Contract

- a. The contractor agrees that it and its employees will not disclose any data obtained or developed under this contract to third parties without the consent of the CPSC.
- b. The contractor shall obtain an agreement of non-disclosure (attached) from each employee who will work on this contract or have access to data obtained or developed under this contract.

XIV. LC 21B Disclosure of Information - Restricted Publication

- a. The contractor shall submit to the CPSC any report, manuscript or other document containing the results of work performed under this contract. This document shall not be published or otherwise disclosed by the contractor.
- b. Should the contractor subsequently apply to the CPSC to publish documents containing the results of this work and the release is approved in writing, any publication of, or publicity pertaining to, the contractor's document shall include the following statement: "This project has been funded with federal funds from the United States Consumer Product Safety Commission under contract number CPSC-S-11-0053. The content of this publication does not necessarily

reflect the views of the Commission, nor does mention of trade names, commercial products, or organizations imply endorsement by the Commission.”

XV. LC1A CONTRACTOR’S NOTE

Deliveries and/or shipments shall not be left at the Loading Dock. **All deliveries shall be considered “inside deliveries”** to the appropriate room at the Consumer Product Safety Commission (CPSC) and in accordance with the instructions below. When scheduling deliveries the purchase order number shall always be referenced and all packages shall clearly display the Purchase Order Number on the outside of the cartons and/or packages, to include the packing slip.

ATTENTION GOVERNMENT VENDOR

A. DELIVERY INSTRUCTIONS:

1. DELIVERY INSTRUCTIONS FOR LARGE OR HEAVY ITEMS:

If the shipment or item being delivered requires use of a loading dock, advance notification is required. The contractor shall contact the Shipping and Receiving Coordinator at (301) 366-7018 or Ronald Welch (301) 504-7091, forty-eight (48) hours in advance of the date the items are to arrive to schedule use of the loading dock.

LOADING DOCK HOURS OF OPERATION:

9:00 am to 11:00 am or 1:30 pm to 4:00 pm
Monday through Friday (except holidays)

Please notify contact person if there is a change in the delivery date. For changes, delays, or assistance please contact CPSC as follows:

Facilities Management Support Services (301) 504-7091
and
Project Officer : Beverly Kohen, 516-938-5215

Upon arrival, the driver should contact the CPSC Guard, 301-504-7721, at the loading dock to obtain assistance in using freight elevators and to gain access to CPSC security areas.

2. DELIVERY INSTRUCTION FOR SMALL ITEMS

When delivering or shipping small items, the contractor and/or carrier service shall report to the 4th floor lobby, North Tower, 4330 East West Highway, to sign in with the CPSC guard. Upon completion of signing in, the contractor shall deliver all shipments to the Mail Room, Room 415. After delivery, delivery personnel shall promptly depart the building.

MAIL ROOM HOURS OF OPERATION:

Monday through Friday (except holidays) – 7:30 am to 5:00 pm

B. BILLING INSTRUCTIONS

Pursuant to the Prompt Payment Act (P.L. 97-177) and the Prompt Payment Act Amendments of 1988 (P.L. 100-496) all Federal agencies are required to pay their bills on time, pay interest penalties when payments are made late, and to take discounts only when payments are made within the discount period. To assure compliance with the Act, vouchers and/or invoices shall be submitted on any acceptable invoice form which meets the criteria listed below. Examples of government vouchers that may be used are the Public Vouchers for Purchase and Services Other Than Personal, SF 1034, and Continuation Sheet, SF 1035. At a minimum, each invoice shall include:

1. The name and address of the business concern (and separate remittance address, if applicable).
2. **Do NOT** include Taxpayer Identification Number (TIN) on invoices sent via e-mail.
3. Invoice date.
4. Invoice number.
5. The contract or purchase order number (see block 2 of OF347 and block 4 of SF1449 on page 1 of this order), or other authorization for delivery of goods or services.
6. Description, price and quantity of goods or services actually delivered or rendered.
7. Shipping cost terms (if applicable).
8. Payment terms.
9. Other substantiating documentation or information as specified in the contract or purchase order.
10. Name, title, phone number and mailing address of responsible official to be notified in the event of a deficient invoice.

ORIGINAL VOUCHERS/INVOICES SHALL BE SENT TO:

U.S. Mail

CPSC Accounts Payable Branch, AMZ-160
PO Box 25710
Oklahoma City, Ok. 73125

FEDEX

CPSC Accounts Payable Branch, AMZ-160
6500 MacArthur Blvd.
Oklahoma City, Ok. 73169

OR

Via email to:

9-AMC-AMZ-CPSC-Accounts-Payable@fas.gov

Invoices not submitted in accordance with the above stated minimum requirements will not be processed for payment. Deficient invoices will be returned to the vendor within seven days or sooner. Standard forms 1034 and 1035 will be furnished by CPSC upon request of the contractor.

Inquiries regarding payment should be directed to the Enterprise Service Center (EXC), Office of Financial Operations, Federal Aviation Administration (FAA) in Oklahoma City, 405-954-7467.

C. PAYMENT

Payment will be made as close as possible to, but not later than, the 30th day after receipt of a proper invoice as defined in "Billing Instructions," except as follows:

When a time discount is taken, payment will be made as close as possible to, but not later than, the discount date. Discounts will be taken whenever economically justified. Otherwise, late payments will include interest penalty payments. Inquiries regarding payment should be directed to Debbie Young at 405-954-7467 or at the U.S. Mail and Fedex addresses listed above:

Complaints related to the late payment of an invoice should be directed to Eldona Canterbury at the same the same address (above) or 405-954-5351.

Customer Service inquiries may be directed to Rachelle Coleman @ rcoleman@cpsc.gov

D. INSPECTION & ACCEPTANCE PERIOD

Unless otherwise stated in the Statement of Work or Description, the Commission will ordinarily inspect all materials/services within seven (7) working days after the date of receipt. The CPSC representative responsible for inspecting the materials/services will transmit disapproval, if appropriate, to the contractor and the contract specialist listed below. If other inspection information is provided in the Statement of Work or Description, it is controlling.

E. ALL OTHER INFORMATION RELATING TO THE PURCHASE ORDER

Contact: Contract Specialist – Germaine Myles at (301) 504-7669

F. PROCESSING INSTRUCTIONS FOR REQUESTING OFFICES

The Purchase Order/Receiving Report (Optional Form 347 or Standard Form 1449) must be completed at the time the ordered goods or services are received. Upon receipt of the goods

or services ordered, each item should be inspected, accepted (partial or final) or rejected. The Purchase Order/Receiving Report must be appropriately completed, signed and dated by the authorized receiving official. In addition, the acceptance block shall be completed (Blocks 32 a, b & c on the SF 1449 and column G and page 2 of the OF 347). The receiving report shall be retained by the requesting office for confirmation when certifying invoices.

G. PROPERTY/EQUIPMENT PURCHASES

In the case of Purchase Orders/Receiving Reports involving the purchase and receipt of property/equipment, a copy of the Purchase Order/Receiving Report must also be immediately forwarded directly to the Property Management Officer (Rey Garcia) in the Facilities Management Support Services Branch (Room 520). The transmittal of Purchase Orders/Receiving Reports to the property management officer is critical to the integrity and operation of CPSC's Property Management System. Receiving officials should also forward copies to their local property officer/property custodian consistent with local office procedures.

XVI. Government-Furnished Supplies/Equipment

The Government will furnish to the contractor, solely for use in connection with the contract, the materials set forth below:

- a. Attachment I – Verification of Compliance Form
- b. Virginia Graeme Baker Pool and Spa Safety Act Public Law 110-140
- c. Pool and Spa Safety Act - Frequently Asked Questions - FAQ
- d. Poster - Staff Guide to Complying with the Law
- e. CPSC Notice of Inspection Form 296A

ATTACHMENT 1



**U.S. Consumer Product Safety Commission
Virginia Graeme Baker Pool and Spa Safety Act
Verification of Compliance Form
COMPLETE A FORM FOR EACH PUMP AT A FACILITY**

PART I – Pool Management Information

OMB Control Number: 3041-0142

Investigator Name		Date of Inspection	
Facility Name		Pool License/Permit Number	
Address	Phone Number ()		
City	State	Zip Code	
Contact Name	Title		
Contact Address			
City	State	Zip Code	
Email Address	Fax #		

PART II – POOL/SPA Information

Pool Location	Indoor <input type="checkbox"/>	Outdoor <input type="checkbox"/>	Water Park <input type="checkbox"/>	Other <input type="checkbox"/>
Pool Type	Swimming Pool <input type="checkbox"/>	Wading Pool <input type="checkbox"/>	Spa <input type="checkbox"/> Hot tub <input type="checkbox"/>	Other <input type="checkbox"/>
Water Features (if any)	Spray <input type="checkbox"/>	Slide <input type="checkbox"/>	Hydro-jet <input type="checkbox"/>	Other <input type="checkbox"/>
Volume of Pool (Gallons)	Mfgr, Make, Model Number, Horse Power of Pump			

Part III – Drain Covers

Total Number of Drain Covers in Pool/Spa <input type="checkbox"/>		Total Number of Drain Covers Installed for VGBA Compliance <input type="checkbox"/>				
Name of Manufacturer of Drain Covers _____		Drain Cover Expiration Date (s) _____				
Drain Cover	Drain Cover Dimensions & Shape (Round, Rectangular, Square, etc.)	Drain Cover & Frame Make and Model Number	Date Installed & Location (Wall or Floor)	Cover Flow Rate per Manufacturer Specifications (gallons per minute)	Pump Flow Rate (gallons per minute)	Cover Conforms to ASME/ANSI A112.19.8-2007 or newer standard (Indicate Yes/No)
1.						
2.						
3.						
4.						
5.						
6.						
7.						
8.						
9.						
10.						

Note: Attach documentation that the drain covers comply with ASME/ANSI A112.19.8 performance standard. (i.e. Professional Engineer inspection report)

Part IV Anti-Entrapment Device/System

1. Single Main Drain Yes No
 Is this an unblockable drain that is larger than 18 x 23? Yes No (If no, go to next section)

2. Multi-Drain System Yes No
 Is the multi-drain system at least three (3) feet from pipe center to pipe center? Yes
 (See Attachment I, page 4) (If no, go to next section)

Select Secondary Backup System that is installed

- Compliant Safety Vacuum Release System (SVRS) (Compliant with ASME/ANSI A112.19.17 or ASTM-F2387)
SVRS Mfgr. Name and Model _____
- Suction- Limiting Vent System
Mfgr. Name and Model Number _____
- Gravity Drainage System _____
- Automatic Pump Shutoff System _____
Mfgr. Name and Model Number _____
- Drain Disablement
Describe how this was accomplished? _____
- Other _____

Comments _____

Part V Sump – Equalizer Lines

Sump Size

Width _____ Depth _____ Length _____

Is Sump existing or new _____ Is it field fabricated or manufactured _____

Describe how it is fabricated? _____

(If field fabricated, attach copy of certification from Professional Engineer)

Manufacturer Name and Model Number _____ Installation Date _____

Clearance between the bottom of the cover and the opening of the suction pipe is _____ (inches)

Equalizer Lines:

Are equalizer lines disabled? (Yes/No) (If so, describe how) _____

Do equalizer lines have covers that cannot be removed? (Yes/No)

Describe how this was accomplished _____

Provide manufacturer name AND model number for each equalizer cover _____

Installation Date _____

Part VI Comments

If pool is not in full compliance , provide a description of actions or steps needed to bring pool or spa into compliance with the Virginia Graeme Baker Pool and Spa Safety Act or attach timeline provided by the pool manager or documentation that drain covers have been ordered.

Comments		
<hr/> <hr/> <hr/> <hr/>		
<hr/>	<hr/>	<hr/>
CPSC Investigator - Print Name	Signature	Date
CPSC Form 120 (07/10)		

Note: This form must be completed by CPSC staff or the designated State or local government official.

CORRECT

3 FEET APART OR MORE

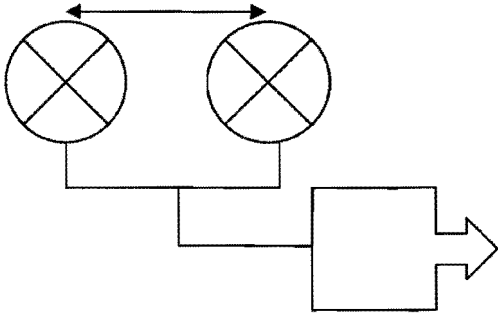

Dual Drain Outlets

CORRECT

3 FEET APART OUTMOST OUTLETS

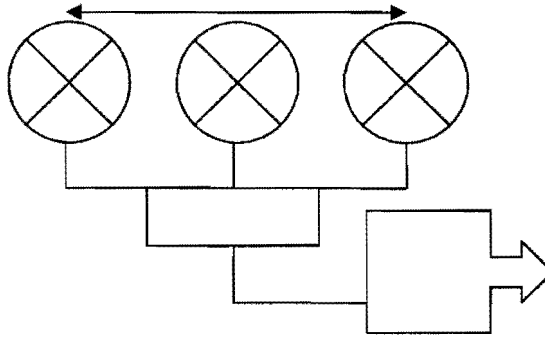

Multiple Drain Outlets

Incorrect

LESS THAN 3 FEET APART

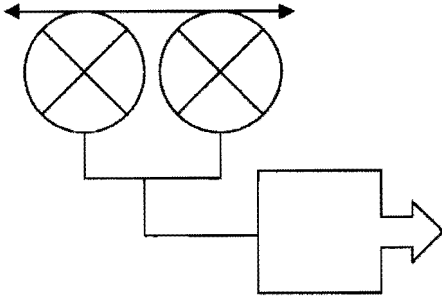

Incorrect

LESS THAN 3 FEET APART FROM OUTMOST OUTLET

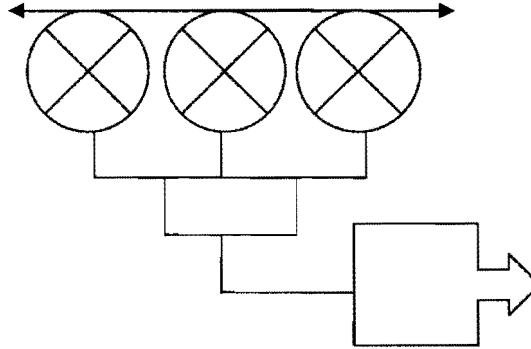

52.212-4 Contract Terms and Conditions - Commercial Items. (JUN 2010)

(a) *Inspection/Acceptance.* The Contractor shall only tender for acceptance those items that conform to the requirements of this contract. The Government reserves the right to inspect or test any supplies or services that have been tendered for acceptance. The Government may require repair or replacement of nonconforming supplies or reperformance of nonconforming services at no increase in contract price. If repair/replacement or reperformance will not correct the defects or is not possible, the Government may seek an equitable price reduction or adequate consideration for acceptance of nonconforming supplies or services. The Government must exercise its post-acceptance rights -

- (1) Within a reasonable time after the defect was discovered or should have been discovered; and
- (2) Before any substantial change occurs in the condition of the item, unless the change is due to the defect in the item.

(b) *Assignment.* The Contractor or its assignee may assign its rights to receive payment due as a result of performance of this contract to a bank, trust company, or other financing institution, including any Federal lending agency in accordance with the Assignment of Claims Act (31 U.S.C. 3727). However, when a third party makes payment (e.g., use of the Governmentwide commercial purchase card), the Contractor may not assign its rights to receive payment under this contract.

(c) *Changes.* Changes in the terms and conditions of this contract may be made only by written agreement of the parties.

(d) *Disputes.* This contract is subject to the Contract Disputes Act of 1978, as amended (41 U.S.C. 601-613). Failure of the parties to this contract to reach agreement on any request for equitable adjustment, claim, appeal or action arising under or relating to this contract shall be a dispute to be resolved in accordance with the clause at FAR 52.233-1, Disputes, which is incorporated herein by reference. The Contractor shall proceed diligently with performance of this contract, pending final resolution of any dispute arising under the contract.

(e) *Definitions.* The clause at FAR 52.202-1, Definitions, is incorporated herein by reference.

(f) *Excusable delays.* The Contractor shall be liable for default unless nonperformance is caused by an occurrence beyond the reasonable control of the Contractor and without its fault or negligence such as, acts of God or the public enemy, acts of the Government in either its sovereign or contractual capacity, fires, floods, epidemics, quarantine restrictions, strikes, unusually severe weather, and delays of common carriers. The Contractor shall notify the Contracting Officer in writing as soon as it is reasonably possible after the commencement of any excusable delay, setting forth the full particulars in connection therewith, shall remedy such occurrence with all reasonable dispatch, and shall promptly give written notice to the Contracting Officer of the cessation of such occurrence.

(g) *Invoice.* (1) The Contractor shall submit an original invoice and three copies (or electronic invoice, if authorized) to the address designated in the contract to receive invoices. An invoice must include--

- (i) Name and address of the Contractor;
- (ii) Invoice date and number;
- (iii) Contract number, contract line item number and, if applicable, the order number;
- (iv) Description, quantity, unit of measure, unit price and extended price of the items delivered;
- (v) Shipping number and date of shipment, including the bill of lading number and weight of shipment if shipped on Government bill of lading;
- (vi) Terms of any discount for prompt payment offered;

(vii) Name and address of official to whom payment is to be sent;

(viii) Name, title, and phone number of person to notify in event of defective invoice; and

(ix) Taxpayer Identification Number (TIN). The Contractor shall include its TIN on the invoice only if required elsewhere in this contract.

(x) Electronic funds transfer (EFT) banking information.

(A) The Contractor shall include EFT banking information on the invoice only if required elsewhere in this contract.

(B) If EFT banking information is not required to be on the invoice, in order for the invoice to be a proper invoice, the Contractor shall have submitted correct EFT banking information in accordance with the applicable solicitation provision, contract clause (e.g., 52.232-33, Payment by Electronic Funds Transfer--Central Contractor Registration, or 52.232-34, Payment by Electronic Funds Transfer--Other Than Central Contractor Registration), or applicable agency procedures.

(C) EFT banking information is not required if the Government waived the requirement to pay by EFT.

(2) Invoices will be handled in accordance with the Prompt Payment Act (31 U.S.C. 3903) and Office of Management and Budget (OMB) prompt payment regulations at 5 CFR part 1315.

(h) *Patent indemnity.* The Contractor shall indemnify the Government and its officers, employees and agents against liability, including costs, for actual or alleged direct or contributory infringement of, or inducement to infringe, any United States or foreign patent, trademark or copyright, arising out of the performance of this contract, provided the Contractor is reasonably notified of such claims and proceedings.

(i) *Payment.* (1) Items accepted. Payment shall be made for items accepted by the Government that have been delivered to the delivery destinations set forth in this contract.

(2) Prompt payment. The Government will make payment in accordance with the Prompt Payment Act (31 U.S.C. 3903) and prompt payment regulations at 5 CFR part 1315.

(3) Electronic Funds Transfer (EFT). If the Government makes payment by EFT, see 52.212-5(b) for the appropriate EFT clause.

(4) Discount. In connection with any discount offered for early payment, time shall be computed from the date of the invoice. For the purpose of computing the discount earned, payment shall be considered to have been made on the date which appears on the payment check or the specified payment date if an electronic funds transfer payment is made.

(5) Overpayments. If the Contractor becomes aware of a duplicate contract financing or invoice payment or that the Government has otherwise overpaid on a contract financing or invoice payment, the Contractor shall--

(i) Remit the overpayment amount to the payment office cited in the contract along with a description of the overpayment including the--

(A) Circumstances of the overpayment (e.g., duplicate payment, erroneous payment, liquidation errors, date(s) of overpayment);

(B) Affected contract number and delivery order number, if applicable;

(C) Affected contract line item or subline item, if applicable; and

(D) Contractor point of contact.

(ii) Provide a copy of the remittance and supporting documentation to the Contracting Officer.

(6) Interest. (i) All amounts that become payable by the Contractor to the Government under this contract shall bear simple interest from the date due until paid unless paid within 30 days of becoming due. The interest rate shall be the interest rate established by the Secretary of the Treasury as provided in Section 611 of the Contract Disputes Act of 1978 (Public Law 95-563), which is applicable to the period in which the amount becomes due, as provided in (i)(6)(v) of this clause, and then at the rate applicable for each six-month period as fixed by the Secretary until the amount is paid.

(ii) The Government may issue a demand for payment to the Contractor upon finding a debt is due under the contract.

(iii) Final decisions. The Contracting Officer will issue a final decision as required by 33.211 if--

(A) The Contracting Officer and the Contractor are unable to reach agreement on the existence or amount of a debt within 30 days;

(B) The Contractor fails to liquidate a debt previously demanded by the Contracting Officer within the timeline specified in the demand for payment unless the amounts were not repaid because the Contractor has requested an installment payment agreement; or

(C) The Contractor requests a deferment of collection on a debt previously demanded by the Contracting Officer (see 32.607-2).

(iv) If a demand for payment was previously issued for the debt, the demand for payment included in the final decision shall identify the same due date as the original demand for payment.

(v) Amounts shall be due at the earliest of the following dates:

(A) The date fixed under this contract.

(B) The date of the first written demand for payment, including any demand for payment resulting from a default termination.

(vi) The interest charge shall be computed for the actual number of calendar days involved beginning on the due date and ending on--

(A) The date on which the designated office receives payment from the Contractor;

(B) The date of issuance of a Government check to the Contractor from which an amount otherwise payable has been withheld as a credit against the contract debt; or

(C) The date on which an amount withheld and applied to the contract debt would otherwise have become payable to the Contractor.

(vii) The interest charge made under this clause may be reduced under the procedures

prescribed in 32.608-2 of the Federal Acquisition Regulation in effect on the date of this contract.

(j) *Risk of loss.* Unless the contract specifically provides otherwise, risk of loss or damage to the supplies provided under this contract shall remain with the Contractor until, and shall pass to the Government upon:

(1) Delivery of the supplies to a carrier, if transportation is f.o.b. origin; or

(2) Delivery of the supplies to the Government at the destination specified in the contract, if transportation is f.o.b. destination.

(k) *Taxes.* The contract price includes all applicable Federal, State, and local taxes and duties.

(l) *Termination for the Government's convenience.* The Government reserves the right to terminate this contract, or any part hereof, for its sole convenience. In the event of such termination, the Contractor shall immediately stop all work hereunder and shall immediately cause any and all of its suppliers and subcontractors to cease work. Subject to the terms of this contract, the Contractor shall be paid a percentage of the contract price reflecting the percentage of the work performed prior to the notice of termination, plus reasonable charges the Contractor can demonstrate to the satisfaction of the Government using its standard record keeping system, have resulted from the termination. The Contractor shall not be required to comply with the cost accounting standards or contract cost principles for this purpose. This paragraph does not give the Government any right to audit the Contractor's records. The Contractor shall not be paid for any work performed or costs incurred which reasonably could have been avoided.

(m) *Termination for cause.* The Government may terminate this contract, or any part hereof, for cause in the event of any default by the Contractor, or if the Contractor fails to comply with any contract terms and conditions, or fails to provide the Government, upon request, with adequate assurances of future performance. In the event of termination for cause, the Government shall not be liable to the Contractor for any amount for supplies or services not accepted, and the Contractor shall be liable to the Government for any and all rights and remedies provided by law. If it is determined that the Government improperly terminated this contract for default, such termination shall be deemed a termination for convenience.

(n) *Title.* Unless specified elsewhere in this contract, title to items furnished under this contract shall pass to the Government upon acceptance, regardless of when or where the Government takes physical possession.

(o) *Warranty.* The Contractor warrants and implies that the items delivered hereunder are merchantable and fit for use for the particular purpose described in this contract.

(p) *Limitation of liability.* Except as otherwise provided by an express warranty, the Contractor will not be liable to the Government for consequential damages resulting from any defect or deficiencies in accepted items.

(q) *Other compliances.* The Contractor shall comply with all applicable Federal, State and local laws, executive orders, rules and regulations applicable to its performance under this contract.

(r) *Compliance with laws unique to Government contracts.* The Contractor agrees to comply with 31 U.S.C. 1352 relating to limitations on the use of appropriated funds to influence certain Federal contracts; 18 U.S.C. 431 relating to officials not to benefit; 40 U.S.C. 3701, et seq., Contract Work Hours and Safety Standards Act; 41 U.S.C. 51-58, Anti-Kickback Act of 1986; 41 U.S.C. 265 and 10 U.S.C. 2409 relating to whistleblower protections; 49 U.S.C. 40118, Fly American; and 41 U.S.C. 423 relating to procurement integrity.

(s) *Order of precedence.* Any inconsistencies in this solicitation or contract shall be resolved by giving precedence in the following order:

(1) The schedule of supplies/services.

(2) The Assignments, Disputes, Payments, Invoice, Other Compliances, and Compliance with

Laws Unique to Government Contracts paragraphs of this clause.

(3) The clause at 52.212-5.

(4) Addenda to this solicitation or contract, including any license agreements for computer software.

(5) Solicitation provisions if this is a solicitation.

(6) Other paragraphs of this clause.

(7) The Standard Form 1449.

(8) Other documents, exhibits, and attachments.

(9) The specification.

(t) Central Contractor Registration (CCR). (1) Unless exempted by an addendum to this contract, the Contractor is responsible during performance and through final payment of any contract for the accuracy and completeness of the data within the CCR database, and for any liability resulting from the Government's reliance on inaccurate or incomplete data. To remain registered in the CCR database after the initial registration, the Contractor is required to review and update on an annual basis from the date of initial registration or subsequent updates its information in the CCR database to ensure it is current, accurate and complete. Updating information in the CCR does not alter the terms and conditions of this contract and is not a substitute for a properly executed contractual document.

(2)(i) If a Contractor has legally changed its business name, "doing business as" name, or division name (whichever is shown on the contract), or has transferred the assets used in performing the contract, but has not completed the necessary requirements regarding novation and change-of-name agreements in FAR subpart 42.12, the Contractor shall provide the responsible Contracting Officer a minimum of one business day's written notification of its intention to (A) change the name in the CCR database; (B) comply with the requirements of subpart 42.12; and (C) agree in writing to the timeline and procedures specified by the responsible Contracting Officer. The Contractor must provide with the notification sufficient documentation to support the legally changed name.

(ii) If the Contractor fails to comply with the requirements of paragraph (t)(2)(i) of this clause, or fails to perform the agreement at paragraph (t)(2)(i)(C) of this clause, and, in the absence of a properly executed novation or change-of-name agreement, the CCR information that shows the Contractor to be other than the Contractor indicated in the contract will be considered to be incorrect information within the meaning of the "Suspension of Payment" paragraph of the electronic funds transfer (EFT) clause of this contract.

(3) The Contractor shall not change the name or address for EFT payments or manual payments, as appropriate, in the CCR record to reflect an assignee for the purpose of assignment of claims (see Subpart 32.8, Assignment of Claims). Assignees shall be separately registered in the CCR database. Information provided to the Contractor's CCR record that indicates payments, including those made by EFT, to an ultimate recipient other than that Contractor will be considered to be incorrect information within the meaning of the "Suspension of payment" paragraph of the EFT clause of this contract.

(4) Offerors and Contractors may obtain information on registration and annual confirmation requirements via the internet at <http://www.ccr.gov> or by calling 1-888-227-2423 or 269-961-5757.

(End of clause)

52.212-5 Contract Terms and Conditions Required To Implement Statutes or Executive Orders--Commercial Items. (APR 2011)

(a) The Contractor shall comply with the following Federal Acquisition Regulation (FAR) clauses, which are incorporated in this contract by reference, to implement provisions of law or Executive orders applicable to acquisitions of commercial items:

- (1) 52.222-50, Combating Trafficking in Persons (FEB 2009) (22 U.S.C. 7104(g)).
- Alternate I (Aug 2007) of 52.222-50 (22 U.S.C. 7104(g)).
- (2) 52.233-3, Protest After Award (AUG 1996) (31 U.S.C. 3553).
- (3) 52.233-4, Applicable Law for Breach of Contract Claim (OCT 2004) (Pub. L. 108-77, 108-78).

(b) The Contractor shall comply with the FAR clauses in this paragraph (b) that the Contracting Officer has indicated as being incorporated in this contract by reference to implement provisions of law or Executive orders applicable to acquisitions of commercial items: Contracting Officer check as appropriate.

- (1) 52.203-6, Restrictions on Subcontractor Sales to the Government (SEP 2006), with Alternate I (OCT 1995) (41 U.S.C. 253g and 10 U.S.C. 2402).
- (2) 52.203-13, Contractor Code of Business Ethics and Conduct (APR 2010)(Pub. L. 110-252, Title VI, Chapter 1 (41 U.S.C. 251 note)).
- (3) 52.203-15, Whistleblower Protections under the American Recovery and Reinvestment Act of 2009 (JUN 2010) (Section 1553 of Pub. L. 111-5). (Applies to contracts funded by the American Recovery and Reinvestment Act of 2009.)
- (4) 52.204-10, Reporting Executive Compensation and First-Tier Subcontract Awards (JUL 2010) (Pub. L. 109-282)(31 U.S.C. 6101 note).
- (5) 52.204-11, American Recovery and Reinvestment Act--Reporting Requirements (JUL 2010) (Pub. L. 111-5).
- (6) 52.209-6, Protecting the Government's Interest When Subcontracting with Contractors Debarred, Suspended, or Proposed for Debarment (DEC 2010) (31 U.S.C. 6101 note). (Applies to contracts over \$30,000). (Not applicable to subcontracts for the acquisition of commercially available off-the-shelf items).
- (7) 52.219-3, Notice of Total HUBZone Set-Aside or Sole-Source Award (JAN 2011) (15 U.S.C. 657a).
- (8) 52.219-4, Notice of Price Evaluation Preference for HUBZone Small Business Concerns (JAN 2011) (if the offeror elects to waive the preference, it shall so indicate in its offer) (15 U.S.C. 657a).
- (9) (Reserved)
- (10)(i) 52.219-6, Notice of Total Small Business Set-Aside (JUN 2003) (15 U.S.C. 644).
 - (ii) Alternate I (OCT 1995) of 52.219-6.
 - (iii) Alternate II (MAR 2004) of 52.219-6.
- (11)(i) 52.219-7, Notice of Partial Small Business Set-Aside (JUN 2003) (15 U.S.C. 644).
 - (ii) Alternate I (OCT 1995) of 52.219-7.

- (iii) Alternate II (MAR 2004) of 52.219-7.
- (12) 52.219-8, Utilization of Small Business Concerns (JAN 2011) (15 U.S.C. 637 (d)(2) and (3)).
- (13)(i) 52.219-9, Small Business Subcontracting Plan (JAN 2011) (15 U.S.C. 637(d)(4)).
 - (ii) Alternate I (OCT 2001) of 52.219-9.
 - (iii) Alternate II (OCT 2001) of 52.219-9.
 - (iv) Alternate III (JUL 2010) of 52.219-9.
- (14) 52.219-14, Limitations on Subcontracting (DEC 1996) (15 U.S.C. 637(a)(14)).
- (15) 52.219-16, Liquidated Damages--Subcontracting Plan (JAN 1999) (15 U.S.C. 637(d)(4)(F)(i)).
- (16)(i) 52.219-23, Notice of Price Evaluation Adjustment for Small Disadvantaged Business Concerns (OCT 2008) (10 U.S.C. 2323)(if the offeror elects to waive the adjustment, it shall so indicate in its offer.)
 - (ii) Alternate I (JUN 2003) of 52.219-23.
- (17) 52.219-25, Small Disadvantaged Business Participation Program--Disadvantaged Status and Reporting (DEC 2010) (Pub. L. 103-355, section 7102, and 10 U.S.C. 2323).
- (18) 52.219-26, Small Disadvantaged Business Participation Program--Incentive Subcontracting (OCT 2000) (Pub. L. 103-355, section 7102, and 10 U.S.C. 2323).
- (19) 52.219-27, Notice of Total Service-Disabled Veteran-Owned Small Business Set-Aside (MAY 2004)(15 U.S.C. 657 f).
- (20) 52.219-28, Post Award Small Business Program Rerepresentation (APR 2009) (15 U.S.C. 632(a)(2)).
- (21) 52.219-29, Notice of Total Set-Aside for Economically Disadvantaged Women-Owned Small Business (EDWOSB) Concerns (APR 2011).
- (22) 52.219-30, Notice of Total Set-Aside for Women-Owned Small Business (WOSB) Concerns Eligible Under the WOSB Program (APR 2011).
- (23) 52.222-3, Convict Labor (JUN 2003) (E.O. 11755).
- (24) 52.222-19, Child Labor--Cooperation with Authorities and Remedies (JUL 2010) (E.O. 13126).
- (25) 52.222-21, Prohibition of Segregated Facilities (FEB 1999).
- (26) 52.222-26, Equal Opportunity (MAR 2007) (E.O. 11246).
- (27) 52.222-35, Equal Opportunity for Veterans (SEP 2010) (38 U.S.C. 4212).
- (28) 52.222-36, Affirmative Action for Workers with Disabilities (OCT 2010) (29 U.S.C. 793).
- (29) 52.222-37, Employment Reports on Veterans (SEP 2010) (38 U.S.C. 4212).

[](30) 52.222-40, Notification of Employee Rights Under the National Labor Relations Act (DEC 2010) (E.O. 13496).

[](31) 52.222-54, Employment Eligibility Verification (JAN 2009). (Executive Order 12989). (Not applicable to the acquisition of commercially available off-the-shelf items or certain other types of commercial items as prescribed in 22.1803.)

[](32)(i) 52.223-9, Estimate of Percentage of Recovered Material Content for EPA-Designated Items (MAY 2008) (42 U.S.C. 6962(c)(3)(A)(ii)). (Not applicable to the acquisition of commercially available off-the-shelf items.)

[](ii) Alternate I (MAY 2008) of 52.223-9 (42 U.S.C. 6962(i)(2)(C)). (Not applicable to the acquisition of commercially available off-the-shelf items.)

[](33) 52.223-15, Energy Efficiency in Energy-Consuming Products (DEC 2007) (42 U.S.C. 8259b).

[](34)(i) 52.223-16, IEEE 1680 Standard for the Environmental Assessment of Personal Computer Products (DEC 2007) (E.O. 13423).

[](ii) Alternate I (DEC 2007) of 52.223-16.

[](35) 52.223-18, Contractor Policy to Ban Text Messaging while Driving (SEP 2010)(E.O. 13513).

[](36) 52.225-1, Buy American Act - Supplies (FEB 2009) (41 U.S.C. 10a-10d).

[](37)(i) 52.225-3, Buy American Act--Free Trade Agreements--Israeli Trade Act (JUN 2009) (41 U.S.C. 10a-10d, 19 U.S.C. 3301 note, 19 U.S.C. 2112 note, 19 U.S.C. 3805 note, Pub. L. 108-77, 108-78, 108-286, 108-302, 109-53, 109-169, 109-283, and 110-138).

[](ii) Alternate I (JAN 2004) of 52.225-3.

[](iii) Alternate II (JAN 2004) of 52.225-3.

[](38) 52.225-5, Trade Agreements (AUG 2009) (19 U.S.C. 2501, et seq., 19 U.S.C. 3301 note).

[](39) 52.225-13, Restrictions on Certain Foreign Purchases (JUN 2008) (E.O.'s, proclamations, and statutes administered by the Office of Foreign Assets Control of the Department of the Treasury).

[](40) 52.226-4, Notice of Disaster or Emergency Area Set-Aside (NOV 2007) (42 U.S.C. 5150).

[](41) 52.226-5, Restrictions on Subcontracting Outside Disaster or Emergency Area (NOV 2007) (42 U.S.C. 5150).

[](42) 52.232-29, Terms for Financing of Purchases of Commercial Items (FEB 2002) (41 U.S.C. 255(f), 10 U.S.C. 2307(f)).

[](43) 52.232-30, Installment Payments for Commercial Items (OCT 1995) (41 U.S.C. 255(f), 10 U.S.C. 2307(f)).

[X](44) 52.232-33, Payment by Electronic Funds Transfer - Central Contractor Registration (OCT 2003) (31 U.S.C. 3332).

[](45) 52.232-34, Payment by Electronic Funds Transfer - Other than Central Contractor Registration (MAY 1999) (31 U.S.C. 3332).

(46) 52.232-36, Payment by Third Party (FEB 2010) (31 U.S.C. 3332).

(47) 52.239-1, Privacy or Security Safeguards (AUG 1996) (5 U.S.C. 552a).

(48)(i) 52.247-64, Preference for Privately Owned U.S.-Flag Commercial Vessels (FEB 2006) (46 U.S.C. Appx 1241(b) and 10 U.S.C. 2631).

(ii) Alternate I (APR 2003) of 52.247-64.

(c) The Contractor shall comply with the FAR clauses in this paragraph (c), applicable to commercial services, that the Contracting Officer has indicated as being incorporated in this contract by reference to implement provisions of law or Executive orders applicable to acquisitions of commercial items: (Contracting Officer check as appropriate.)

(1) 52.222-41, Service Contract Act of 1965 (NOV 2007) (41 U.S.C. 351, et seq.).

(2) 52.222-42, Statement of Equivalent Rates for Federal Hires (MAY 1989) (29 U.S.C. 206 and 41 U.S.C. 351, et seq.).

(3) 52.222-43, Fair Labor Standards Act and Service Contract Act--Price Adjustment (Multiple Year and Option Contracts) (SEP 2009) (29 U.S.C. 206 and 41 U.S.C. 351, et seq.).

(4) 52.222-44, Fair Labor Standards Act and Service Contract Act--Price Adjustment (SEP 2009) (29 U.S.C. 206 and 41 U.S.C. 351, et seq.).

(5) 52.222-51, Exemption from Application of the Service Contract Act to Contracts for Maintenance, Calibration, or Repair of Certain Equipment--Requirements (NOV 2007) (41 U.S.C. 351, et seq.).

(6) 52.222-53, Exemption from Application of the Service Contract Act to Contracts for Certain Services--Requirements (FEB 2009) (41 U.S.C. 351, et seq.).

(7) 52.226-6, Promoting Excess Food Donation to Nonprofit Organizations. (MAR 2009) (Pub. L. 110-247).

(8) 52.237-11, Accepting and Dispensing of \$1 Coin (SEP 2008) (31 U.S.C. 5112(p)(1)).

(d) *Comptroller General Examination of Record.* The Contractor shall comply with the provisions of this paragraph (d) if this contract was awarded using other than sealed bid, is in excess of the simplified acquisition threshold, and does not contain the clause at 52.215-2, Audit and Records - Negotiation.

(1) The Comptroller General of the United States, or an authorized representative of the Comptroller General, shall have access to and right to examine any of the Contractor's directly pertinent records involving transactions related to this contract.

(2) The Contractor shall make available at its offices at all reasonable times the records, materials, and other evidence for examination, audit, or reproduction, until 3 years after final payment under this contract or for any shorter period specified in FAR Subpart 4.7, Contractor Records Retention, of the other clauses of this contract. If this contract is completely or partially terminated, the records relating to the work terminated shall be made available for 3 years after any resulting final termination settlement. Records relating to appeals under the disputes clause or to litigation or the settlement of claims arising under or relating to this contract shall be made available until such appeals, litigation, or claims are finally resolved.

(3) As used in this clause, records include books, documents, accounting procedures and practices, and other data, regardless of type and regardless of form. This does not require the Contractor to create or maintain any record that the Contractor does not maintain in the ordinary course of

business or pursuant to a provision of law.

(e)(1) Notwithstanding the requirements of the clauses in paragraphs (a), (b), (c), and (d) of this clause, the Contractor is not required to flow down any FAR clause, other than those in this paragraph (e)(1) in a subcontract for commercial items. Unless otherwise indicated below, the extent of the flow down shall be as required by the clause--

(i) 52.203-13, Contractor Code of Business Ethics and Conduct (APR 2010) (Pub. L. 110-252, Title VI, Chapter 1 (41 U.S.C. 251 note)).

(ii) 52.219-8, Utilization of Small Business Concerns (DEC 2010) (15 U.S.C. 637(d)(2) and (3)), in all subcontracts that offer further subcontracting opportunities. If the subcontract (except subcontracts to small business concerns) exceeds \$650,000 (\$1.5 million for construction of any public facility), the subcontractor must include 52.219-8 in lower tier subcontracts that offer subcontracting opportunities.

(iii) (Reserved)

(iv) 52.222-26, Equal Opportunity (MAR 2007) (E.O. 11246).

(v) 52.222-35, Equal Opportunity for Veterans (SEP 2010) (38 U.S.C. 4212).

(vi) 52.222-36, Affirmative Action for Workers with Disabilities (OCT 2010) (29 U.S.C. 793).

(vii) 52.222-40, Notification of Employee Rights Under the National Labor Relations Act (DEC 2010) (E.O. 13496). Flow down required in accordance with paragraph (f) of FAR clause 52.222-40.

(viii) 52.222-41, Service Contract Act of 1965 (NOV 2007) (41 U.S.C. 351, et seq.).

(ix) 52.222-50, Combating Trafficking in Persons (FEB 2009) (22 U.S.C. 7104(g)).

Alternate I (AUG 2007) of 52.222-50 (22 U.S.C. 7104(g)).

(x) 52.222-51, Exemption from Application of the Service Contract Act to Contracts for Maintenance, Calibration, or Repair of Certain Equipment--Requirements (NOV 2007) (41 U.S.C. 351, et seq.).

(xi) 52.222-53, Exemption from Application of the Service Contract Act to Contracts for Certain Services-Requirements (FEB 2009)(41 U.S.C. 351, et seq.).

(xii) 52.222-54, Employment Eligibility Verification (JAN 2009).

(xiii) 52.226-6, Promoting Excess Food Donation to Nonprofit Organizations. (MAR 2009) (Pub. L. 110-247). Flow down required in accordance with paragraph (e) of FAR clause 52.226-6.

(xiv) 52.247-64, Preference for Privately Owned U.S.-Flag Commercial Vessels (FEB 2006) (46 U.S.C. Appx 1241(b) and 10 U.S.C. 2631). Flow down required in accordance with paragraph (d) of FAR clause 52.247-64.

(2) While not required, the contractor may include in its subcontracts for commercial items a minimal number of additional clauses necessary to satisfy its contractual obligations.

(End of clause)

52.217-9 Option to Extend the Term of the Contract (Mar 2000)

(a) The Government may extend the term of this contract by written notice to the Contractor within 30 days provided that the Government gives the Contractor a preliminary written notice of its intent to extend at least 45 days before the contract expires. The preliminary notice does not commit the Government to an extension.

(b) If the Government exercises this option, the extended contract shall be considered to include this option clause.

(c) The total duration of this contract, including the exercise of any options under this clause, shall not exceed two (2) years..

(End of clause)